

# MR340-1

## Fiber Optic Incremental Encoder

### DIN Rail Mount Controller

## Instruction Manual

Document: 98-0340-12  
Revision: A (Interim Release)

#### IMPORTANT NOTE

This is an interim release of the MR340-1 Instruction Manual based on the MR302-1 Controller and MR302-Zappy Configuration Software. All references to MR302-1 shall be applicable to the MR340-1. A new version of this manual will be available concurrent with the release of the Zappy340 software. The MR340-1 Controller is compatible with all MR34X series sensors as well as MR303 and MR304.

Internal references to the MR303 and MR304 sensors shall apply to the MR343 and MR341, respectively. This is a part number change only.

MICRONOR INC.  
900 Calle Plano, Suite K  
Camarillo, CA 93012 USA  
T +1-805-389-6600  
F +1-805-389-6605  
support@micronor.com  
[www.micronor.com](http://www.micronor.com)

For Support in Europe:

MICRONOR AG  
Pumpwerkstrasse 32  
CH-8105 Regensdorf  
Switzerland  
T +41-44-843-4020  
F +41-44-843-4039  
support@micronor.ch  
[www.micronor.com](http://www.micronor.com)

#### Notice of Proprietary Rights

The design concepts and engineering details embodied in this manual, which are the property of MICRONOR INC., are to be maintained in strict confidence; no element or detail of this manual is to be spuriously used, nor disclosed, without the express written permission of MICRONOR INC. All rights are reserved. No part of this publication may be reproduced, stored in a retrieval system, or transmitted in any form or by any means, electronic, mechanical, photocopying, recording, or otherwise, without prior written permission from MICRONOR INC.

Document 98-0430-12 Revision History

REV	Date	Notes
A	6/22/2018	Initial Release-Same as MR302-1

## Table of Contents

1.	Product Description .....	6
1.1	Incremental Encoder Background.....	6
1.2	Fiber Optic Incremental Sensor .....	6
2.	Initial Preparation .....	9
2.1	Unpacking and Inspection .....	9
2.2	Damage in Shipment .....	9
2.3	Standard Contents.....	9
3.	Installation and Operation.....	10
3.1	Mounting the Sensor Unit.....	10
3.2	Mounting the MR302-1 Controller Module.....	11
3.3	Optical Connections to the Controller .....	12
3.3.1	Cleaning Fiber Optic Connections.....	13
3.4	Electrical Connections To Controller.....	14
3.4.1	Main Electrical Connections.....	14
3.4.2	Interfacing With a Motor Driver .....	15
3.4.3	SSI and RS485 Interface Connections (J3).....	16
3.4.4	USB Interface (J2).....	17
3.4.5	Programmable Analog Output – Current or Voltage Connections.....	17
3.5	How To Install the MR303 Linear Encoder .....	20
3.5.1	Film Mounting and Handling With MR303.....	20
3.5.2	Initial Optical Power Level Referencing When Using Film .....	22
3.5.3	Indexing for Linear Absolute Position .....	23
3.6	Power-up or Periodic Optical Sensitivity Calibration .....	24
3.6.1	Optical sensitivty calibration for linear sensors .....	24
3.6.2	Optical sensitivty calibration for rotary sensors .....	24
3.7	Initial System Configuration and Power-Up Examples.....	25
3.7.1	Rotary Encoder Configuration and Operation.....	25
3.7.2	Linear Encoder With Film And Using HOMING Function.....	27
3.7.3	Linear Encoder With Film Without HOMING Region .....	29
4.	Modbus Serial Communications.....	31
4.1	Modbus Serial Interface .....	31
4.2	MODBUS Communications Protocol .....	33
4.3	Detailed Description of Each Function.....	41
4.3.1	Counter (Register 0x001) .....	41
4.3.2	Speed /RPM output (Register 0x003).....	41
4.3.3	Voltage Mode (Register 0x200).....	42
4.3.4	Voltage Scale (Register 0x201).....	43
4.3.5	Voltage Filter (Register 0x203).....	44
4.3.6	Current Mode (Register 0x204).....	45
4.3.7	Current Scale (Register 0x205).....	48

4.3.8	Current Filter (Register 0x207) .....	48
4.3.9	Counter Reset Mode (Register 0x208) .....	49
4.3.10	Counter Reset (Register 0x209).....	50
4.3.11	Quadrature Edge Multiplier (Register 0x211).....	50
4.3.12	Turn Direction (Register 0x20B) .....	51
4.3.13	Line Driver Output Voltage (Register 0x214).....	52
4.3.14	Analog Output Select (Register 0x215).....	52
4.3.15	EEPROM SET (FC05-2).....	53
4.4	Error Handling and Troubleshooting .....	54
4.4.1	Explanation of Status and Error Handling .....	54
4.4.2	Explanation of Status and Error Indication .....	54
4.4.3	Reading The Error Counters .....	59
5.	Warranty Information.....	60
6.	Specifications .....	61
6.1	MR302-1 DIN Rail Mount Controller .....	61
6.2	MR303 Linear Sensor .....	62
6.3	MR304 Rotary Sensor.....	63
7.	ZAPPY® 302 SOFTWARE.....	64
7.1	How To Install and Use Zappy® 302.....	64
7.2	ZAPPY® Menu Screens.....	64
7.2.1	System Functions screen.....	64
7.2.2	User Functions screen.....	66
7.2.3	Service Functions screen.....	67
7.2.4	Command List screen .....	68
8.	MR302 Theory of Operation.....	69
9.	MR302 -1 Reprogramming the Firmware .....	71
9.1	DAMAGED Firmware Recovery .....	74
10.	Mechanical Reference Drawings.....	75
10.1	MR340-1 Controller.....	75
10.2	MR340 Series Declaration of Conformity.....	75

## Figures

Figure 1.	Controller works with both MR303 Linear and MR304 Rotary Encoders.....	10
Figure 2.	Keep LC Duplex connector ends protected when not in use .....	10
Figure 3.	Mounting to 35mm DIN Rail .....	11
Figure 4.	Mounting to Wall Using Screws.....	11

Figure 5. Connecting fiber cable.....	12
Figure 6. Clean Receptacle with the supplied Cleaning Stick.....	13
Figure 7. Clean Optical Plug with supplied Clean Wipes .....	13
Figure 8. Location of SSI, RS485/Modbus RTU, and USB Connections .....	16
Figure 9. J3-Connector Pin Assignments .....	16
Figure 10. Plug for J3 Connector .....	17
Figure 11. Connection for 4-20mA current loop .....	18
Figure 12. Connection for Voltage Output.....	18
Figure 13. Positioning film inside MR303 sensor.....	20
Figure 14. The emulsion side is up when right side reading text .....	20
Figure 15. Filmstrip dimensions .....	21
Figure 16. Location of internal CAL button for initial optical level calibration .....	22
Figure 17. ZAPPY® System Functions screen.....	65
Figure 18. ZAPPY® User Functions screen.....	66
Figure 19. ZAPPY® Service Functions screen.....	67
Figure 20. ZAPPY® Command List screen .....	68
Figure 21. Block Diagram of MR302 Controller.....	69

# 1. Product Description

## 1.1 Incremental Encoder Background

Incremental encoders are typically used to sense the motion and speed of a motor shaft. Typically the encoder outputs two phase-shifted signals. Depending on the direction of movement, the phase shift is either  $+90^\circ$  or  $-90^\circ$ , this signal is referred to as the Quadrature Signal.

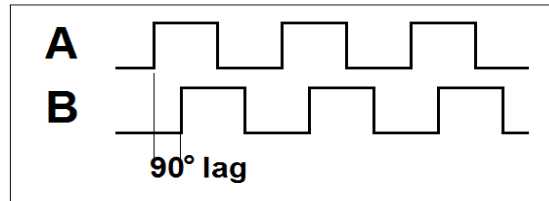

Typically these encoders incorporate electronics and are susceptible to electrical interferences (EMI/RFI). Examples include:

- Pipe and tube welding produces extreme interference while the welding process is active
- MRI machines operate under an extremely strong electromagnetic field
- Surgical robots must perform 100% reliably
- Aerospace actuators operate in and around other noise generating avionics

An all-optical, non-electronic passive solution such as the fiber optic encoder provides completely immunity to such interferences.

## 1.2 Fiber Optic Incremental Sensor

The MR30X series fiber optic incremental encoder system is an innovative all-optical design immune to any electro-magnetic interference such as lightning, radiation, magnetic fields and other harsh environmental conditions. The fiber optic aspect of the sensor also makes it perfectly suited for long distance speed and position sensing over hundreds of meters without being affected by ground loop problems.

This innovative product can be fitted to an existing DC motor or it is available as a stand-alone encoder.

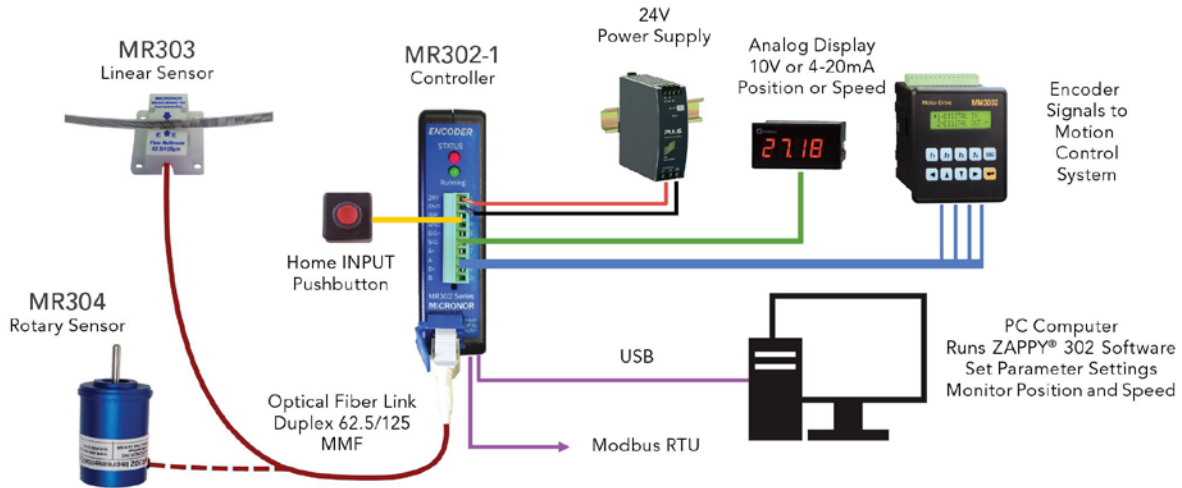

The controller module sends two separate optical wavelength signals to the encoder. The encoder then modulates each optical beam based on the direction with a leading or lagging phase shift.

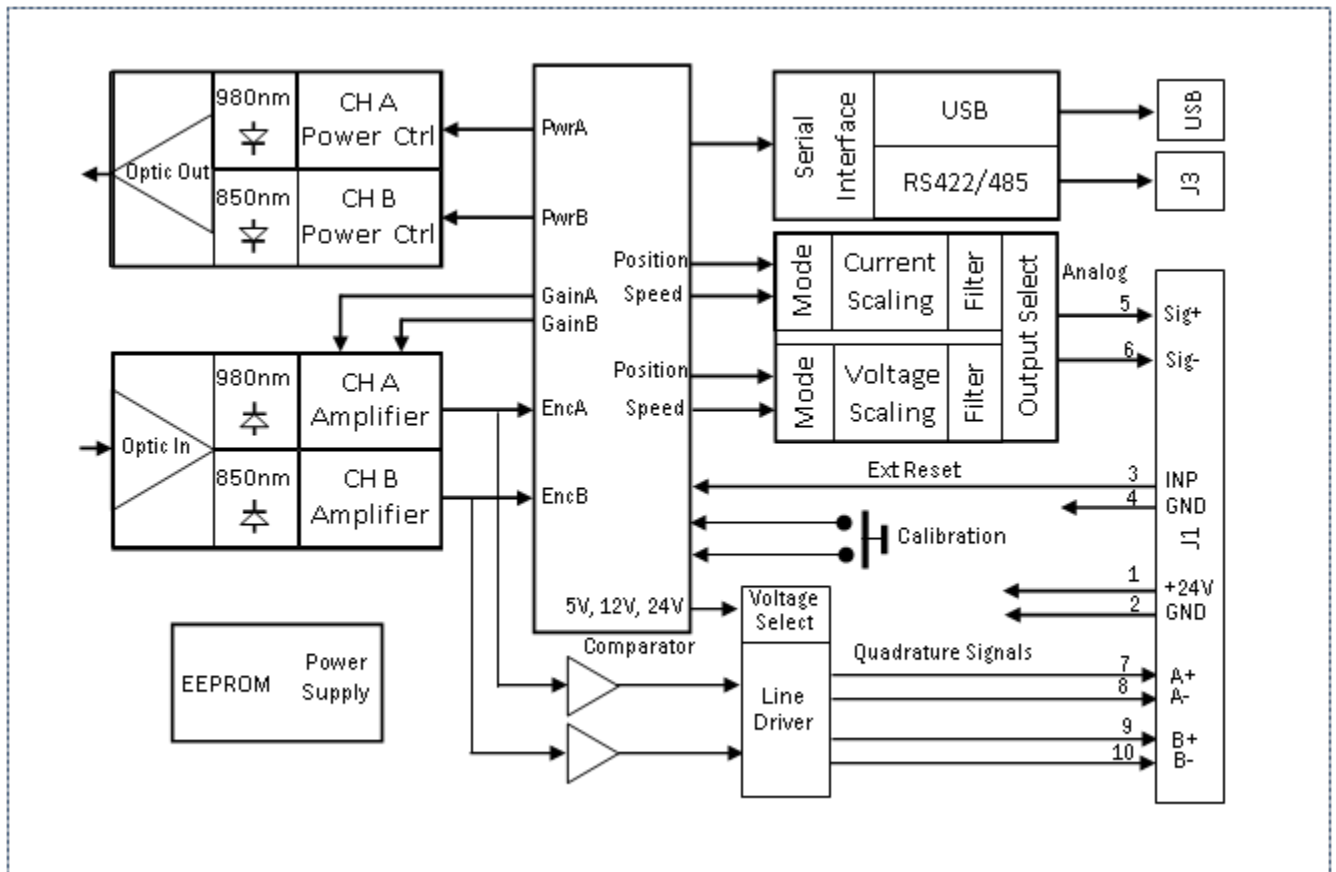

The return optical signals are split up into two separate beams and converted back into an electrical signal.

A microprocessor is used to supervise the amplitude of the optical signals and constantly adjust the signal as to provide a stable quadrature output.

The microprocessor has built-in error checking and will signal any anomaly within the operation of the sensor system

## 2. Initial Preparation

### 2.1 Unpacking and Inspection

The unit was carefully inspected mechanically and electrically before shipment. When received, the shipping carton should contain the following items listed below. Account for and inspect each item before the carton is discarded.

In the event of a damaged instrument, write or call your nearest MICRONOR sales office.

Please retain the shipping container in case re-shipment is required for any reason.

### 2.2 Damage in Shipment

If you receive a damaged instrument you should:

- 1) Report the damage to your shipper immediately.
- 2) Inform MICRONOR
- 3) Save all shipping cartons.

Failure to follow this procedure may affect your claim for compensation.

### 2.3 Standard Contents

MR303 Linear Sensor:

- MR303 series sensor with optical pigtail length as ordered and terminated with Duplex LC connector. Examples: MR303, MR304, etc.
- Instruction Manual (this document, one soft copy supplied with each shipment)

MR304 Rotary Sensor:

- MR304 series sensor with optical pigtail length as ordered and terminated with Duplex LC connector. Examples: MR303, MR304, etc.
- Instruction Manual (this document, one soft copy supplied with each shipment)

MR302-1 Controller Module:

- MR302-1 Controller
- Instruction Manual (this document, one soft copy supplied with each shipment)
- MR321C Fiber Optic Cleaning Kit (one supplied per shipment)

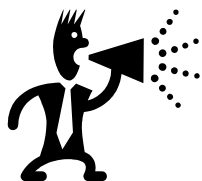

Both this Instruction Manual and ZAPPY® 302 software can also be download from [www.micronor.com](http://www.micronor.com)

### 3. Installation and Operation

#### 3.1 Mounting the Sensor Unit

Various different types of sensors will work in conjunction with the MR302-1 Controller.

MR304 series Rotary Encoder offers small size and resolution up to 512ppr.

MR303 Linear Encoder is a special read-head sensor that can be used to measure linear movement. It is constructed of both non-metallic and non-ferrous materials. The sensor is safe for use within or around MRI equipment, or within other extreme electromagnetic fields.

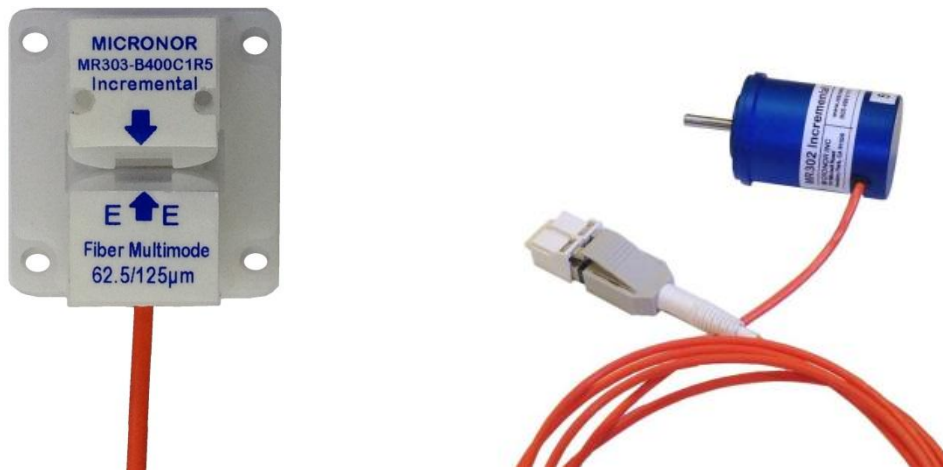

Figure 1. Controller works with both MR303 Linear and MR304 Rotary Encoders

When installing the sensor, be careful not to bend the fiber excessively. It is recommended to keep the minimum bend radius 25mm (1") or larger. Ensure the fiber outlet at the encoder is protected from excessive pulling or bending.

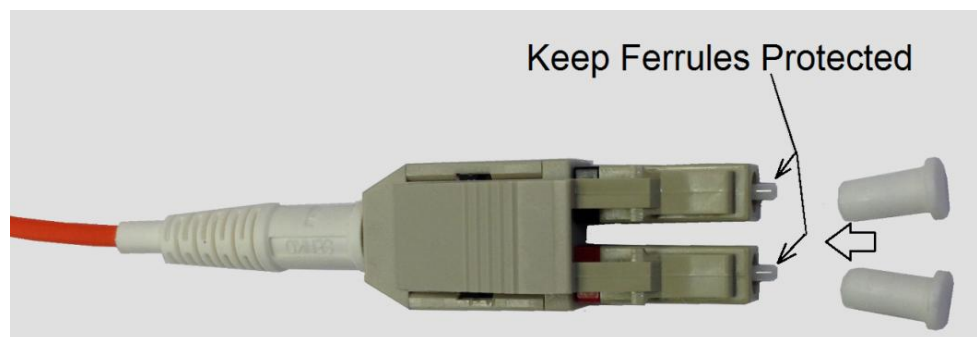

Figure 2. Keep LC Duplex connector ends protected when not in use

Make sure fiber optic connector tips are always covered when not in use. Always clean and inspect the connector ends before mating to interface.

Be sure to use proper fiber optic cleaning tools and procedures such as the Micronor MR321C Cleaning Kit. Improper tools and/or processes may damage or contaminate the optical interface.

### 3.2 Mounting the MR302-1 Controller Module

The controller unit mounts on standard 35mm DIN rail or it can be screw mounted to a wall or cabinet. For DIN rail mounting, insert clip to the unit and then clip onto DIN rail by bending the clip tabs toward the enclosure. When screw mounting, remove clip from enclosure and use screws to affix clip to the wall and then clip enclosure onto the plastic clip. Both mounting schemes are shown below in Figure 3 and Figure 4.

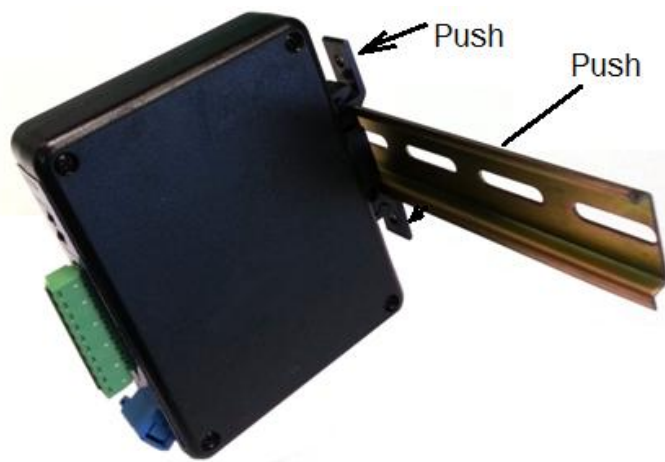

Figure 3. Mounting to 35mm DIN Rail



Figure 4. Mounting to Wall Using Screws

### 3.3 Optical Connections to the Controller

A duplex fiber optic cable is used to interconnect the sensor and controller. The sensor incorporates a 1.5m optical pigtail (or as specified by customer). If a longer connection to the controller is required, then an extension fiber cable having duplex LC connector may be used.

Remove the dust cap from the connector on the cable and open the spring-loaded cover of the receptacle on the controller. Insert the LC connector as shown. There should be a positive click when the connector is engaged properly.

Do not force the Fiber Optic Connector!

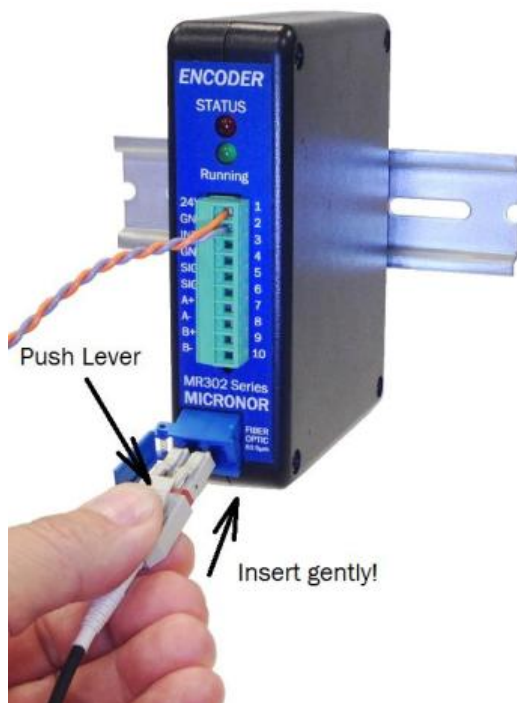
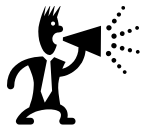

Figure 5. Connecting fiber cable

This is the same fiber used in local area networks (LANs). The cable ends must be terminated with high quality Duplex LC connectors and meet these optical performance requirements:

- Multimode Fiber 62.5/125 $\mu$ m, 0.275NA
- Insertion loss <0.5dB,
- Return loss >20dB
- End-face geometry per TELCORDIA GR-326-CORE or equivalent

### 3.3.1 Cleaning Fiber Optic Connections



- Fiber Optic connectors must be kept clean from dust and other contaminants.
- Always keep unmated connectors covered with an appropriate dust cap.
- Do not touch the connector ends.

Micronor supplies the MR321C cleaning kit with every system order. Before mating - clean BOTH connector ends as shown below in Figure 6 and Figure 7.

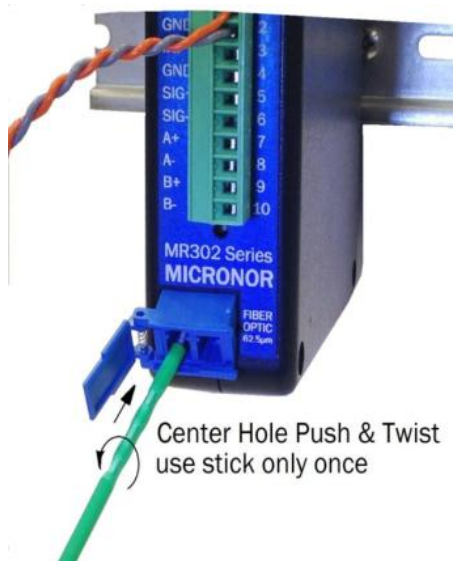
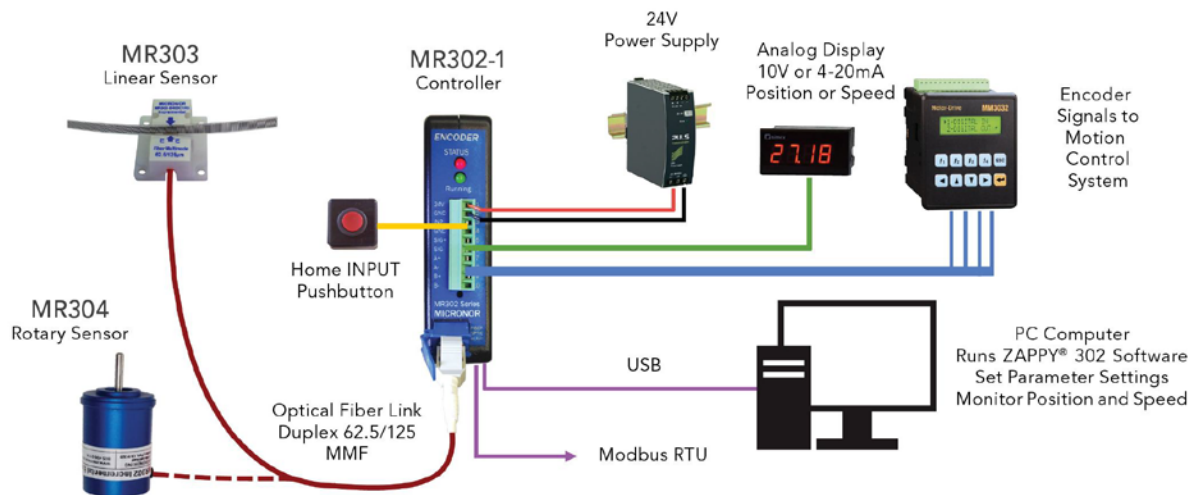

Figure 6. Clean Receptacle with the supplied Cleaning Stick



Figure 7. Clean Optical Plug with supplied Clean Wipes

### 3.4 Electrical Connections To Controller



The MR302-1 controller requires a 24V DC power supply delivering a minimum of 100mA current. The Fiber Optic Sensor shall be connected via the Duplex LC Fiber Optic cable. Fiber Optic extension cables interconnected via Duplex LC mating adapters may also be used.

Connections from the controller to the users equipment depends on the application. For a motor drive controlling the speed, the quadrature signals must be connected to the encoder inputs of the motor drive. The user can configure the differential outputs to provide 5V, 12V or 24V signal levels. The factory setting is 5V. (Consult section 8.1 User Parameter Settings)

If the sensor system is used to display position or speed, an analog panel meter may be connected to the analog signal output (SIG+/SIG-). The output can be programmed for either Voltage ( $\pm 10V$ ) or current (4-20mA) as well as freely scaled to indicate either position or speed. (Consult section 8.1 User Parameter Settings)

An external HOMING Input is available to connect a "Homing Switch" allowing the system to calibrate to an absolute position at start-up. This input offers additional functionality. (Consult section 8.1 User Parameter Settings)

#### 3.4.1 Main Electrical Connections

The unit is powered by 24 VDC with maximum 100mA current consumption.  
Encoder output levels are User Selectable via Zappy® 302: 5V, 12V or 24V  
Serial Interface is Modbus RS485/RS422 compatible.  
Default baud-rate 57600, 8bit, 1 stop, no parity  
Default address 235

10C Screw Terminal Plug, Accepts 14 AWG to 30 AWG wires Phoenix P/N 1803659 (one supplied with the controller)		
Pin	Function	Notes
1	+24V	Power Supply, 50mA Typical
2	GND	
3	INPUT	+24V Homing Input for Calibrating Absolute Position
4	GND	
5	SIG+	User Selectable Analog Output: ±10V or 4-20mA
6	SIG-	
7	A+	User Selectable A/B Quadrature Output Level: 5V, 12V, 24V:
8	A-	
9	B+	
10	B-	



### 3.4.2 Interfacing With a Motor Driver

One common application for any encoder is to provide position and velocity information to a servo drive. In this example, the A/B quadrature signals are connected directly to the encoder inputs of the servo drive which internally tracks the motor status.

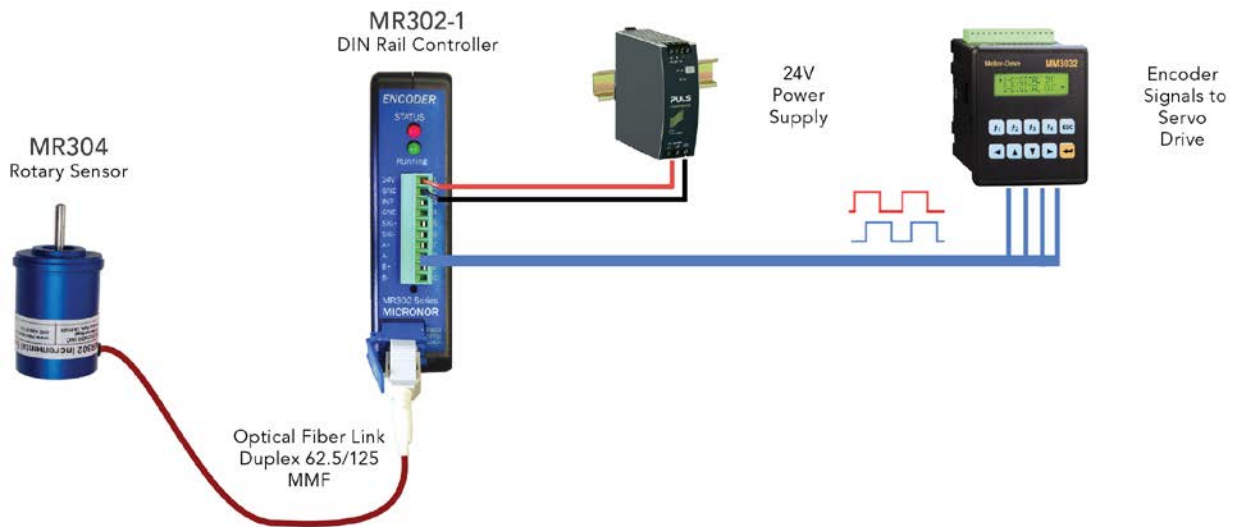

### 3.4.3 SSI and RS485 Interface Connections (J3)

Connector J2 provides USB interface with Type B connection.  
 Connector J3 provides both RS485 and SSI interfaces.



Figure 8. Location of SSI, RS485/Modbus RTU, and USB Connections



RS485 via J3		SSI via J3	(Optional) MR430-99-01 Color Code
Pin	Function	Color	Color
1	+5V	+5V	Brown
2	RS422 – RCV- (input)		Red
3	RS422 – RCV+(input)		Orange
4	RS422 – TX- (output)		Yellow
5	RS422 – TX+(output)		Green
6	GND	GND	Blue
7		SSI-CLK-	Purple
8		SSI-CLK+	Grey
9		SSI-DAT-	White
10		SSI-DAT+	Black

NOTE: Pin 1 (+5V Power) can be used to power an RS232 to RS485 converter module.

Figure 9. J3-Connector Pin Assignments

Default Baud rate is: 57600, 8 bit data, 1stop bit, no parity bit



Connector Plug: Hirose P/N 3240-10P-C(50)  
 Digikey P/N H11343-ND  
 Mouser P/N 798-324010PC50

Recommended Cable:  
 Tensility International P/N 30-00534  
 Digikey P/N T1355-5-ND

Micronor P/N MR430-99-01 (available separately) is a pre-assembled pigtail assembly with 1m pigtail

Figure 10. Plug for J3 Connector

### 3.4.4 USB Interface (J2)

For configuring the controller parameters, the USB interface (J2) is best used along with the ZAPPY@302 software. Communication is via the FTDI chip ([www.ftdichip.com](http://www.ftdichip.com)) and the computer must have the Virtual Com Port (VCP) interface driver installed. If internet access is available, Windows operating systems will install the driver automatically when the unit is plugged in the first time. If not, visit the FTDI website and search for the VCP driver appropriate for your operating system.

Note: The controller module is not USB powered and requires an external 24V power supply.

### 3.4.5 Programmable Analog Output – Current or Voltage Connections

The analog output of the MR302-1 Controller is user settable for either current or voltage output. This section assumes that the user has already programmed the analog output for one of these modes – using the supplied ZAPPY@302 configuration software.

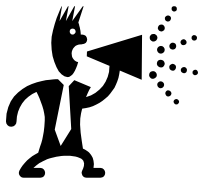

An internal relay configures the function of terminals 5 and 6 to either current output or voltage output.

- When set to current mode, the terminals 5 & 6 are isolated.
- When set to voltage output, terminal 5 is the positive output and terminal 6 is internally connected to system GND with terminals 2 and 4.

#### Current Output Connection

The current output of the MR302-1 controller is an isolated, loop-powered current source. The user must provide an in line power source for proper operation.

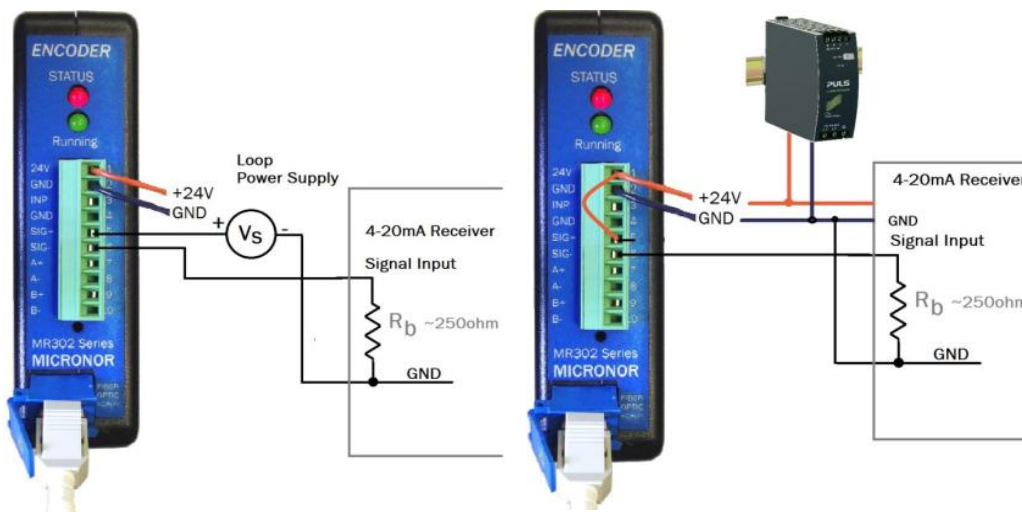
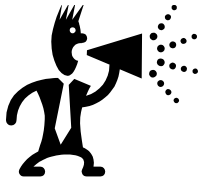

Figure 11. Connection for 4-20mA current loop

The current loop requires a voltage source. However that voltage source may come from the same power supply which powers both the encoder controller and the 4-20mA current receiver.

The MR302-1 current output has an internal voltage requirement of 7.5V. Thus the maximum burden including wiring resistance should be less than:

- $R_{bmax} = (24V - 7.5V) / 20mA = 825ohm.$
- In practice, the burden resistance should not exceed 500 ohms.



**CAUTION**

Before connecting a voltage source to the Current output, make sure to set this parameter to current output. Otherwise the voltage output will attempt to drive against the applied voltage source.

**Voltage Output Connection**

The current output of the MR302-1 controller is an isolated, loop-powered current source. The user must provide in line power source for proper operation.

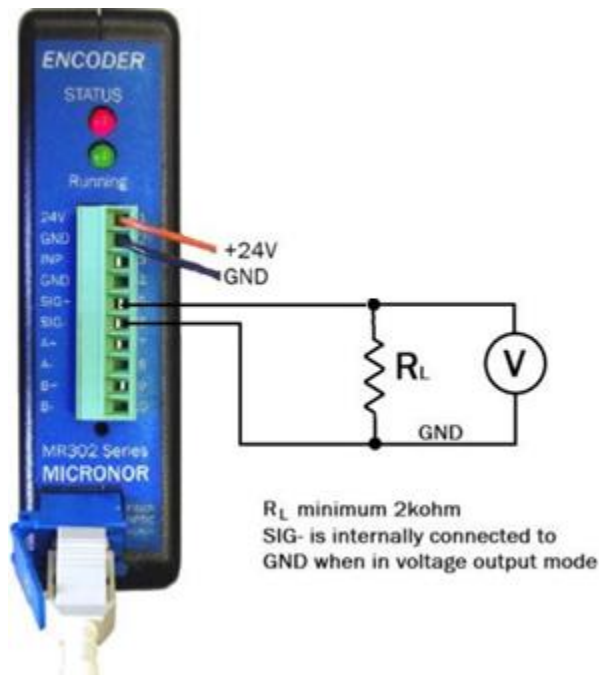

Figure 12. Connection for Voltage Output



### 3.5 How To Install the MR303 Linear Encoder

#### 3.5.1 Film Mounting and Handling With MR303

Although the film positioning within the sensor slit is not critical, it should be mounted in such a way that it is as parallel to the sensor pick-up head as possible. Ideally the film should be mounted so it is perpendicular to the sensor head and always lay against one side of the slit. The film should be prevented from wobbling within the slit.

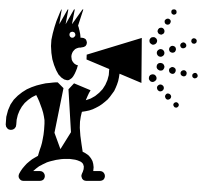

Emulsion side of film must face side where the fiber enters the sensor.

Be careful when handling film to not leave fingerprints.

After film strip is inserted into sensor, either use the supplied clip or cover to secure film and maintain proper alignment.

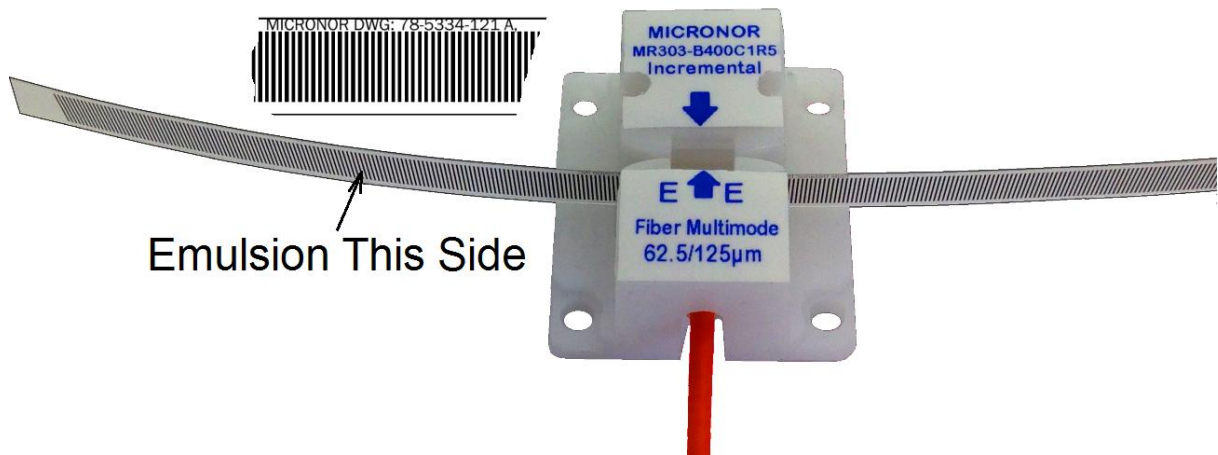

Figure 13. Positioning film inside MR303 sensor



Figure 14. The emulsion side is up when right side reading text

To protect the film from scratches where the light senses the lines, the assembly has a slight recess. It is therefore important that the film is operated sliding at the bottom of the assembly. The high precision optical read head is very high precision and is sensitive to scratches or dust on the film. Scratches of 50µm or more can cause an erroneous pulse.

Positioning the film affects the ultimate performance of the system. Apply just enough pull to the film so as it is stretched at all times. Too much pull will increase pressure on the read surface and may lead to high wear of the film. Typically 50-100 grams of pull force is sufficient.

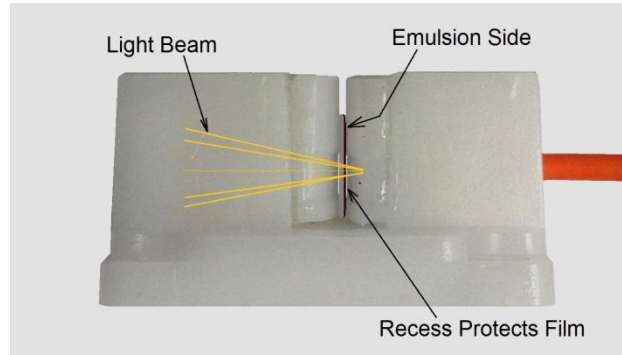

When using a film with 0.4mm line spacing, it is possible to obtain 0.1mm resolution. Consult Figure 12 below for recommended film strip dimensions. Each opaque and translucent cycle will need to be a total of 400µm.

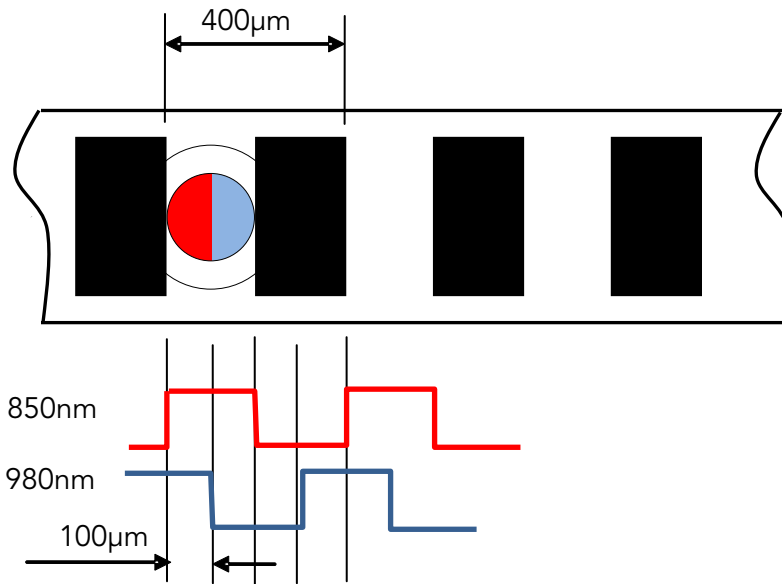

Figure 15. Filmstrip dimensions

As can be seen in Figure 12, positional accuracy is given by the film itself and the shape of the light beam. The film is made accurately to within  $\pm 3\mu\text{m}$ . The absolute edge accuracy is approx.  $\pm 25\%$  of the slit width. With the design, as shown above, the very worst case deviation is  $\pm 50\mu\text{m}$  maximum. Typically  $\pm 25\mu\text{m}$  can be expected.

Thermal expansion of the film tape is typically  $22\mu\text{m}/\text{m}/^\circ\text{C}$ . With the temperature variation within an MRI environment being minimal, this deviation is not a factor in accuracy when operating at normal room temperature. The film base material is highly stable.

To obtain a balanced signal with a duty cycle of 50% and a phase shift of  $90^\circ$ , the distance from the optical fiber to the film must be accurately controlled within the pick-up assembly. This is a factory-only adjustment.

### 3.5.2 Initial Optical Power Level Referencing When Using Film

After initial installation, it is important that the optical power levels (one level for each quadrature channel) are calibrated to the nominal operating level. This is required to compensate for fiber optic connector losses and variation between sensors and controllers. The MR302-1 controller is designed to perform this calibration procedure automatically once initiated by the user.

- Install the sensor, film, the controller and make all fiber connections.
- Set the sensor to a clear area of the film where there are no obstructions.
- Press the internal "CAL" button on the controller for 10 seconds. The PWR LED will blink while the calibration is being performed. After ~10 seconds, the STATUS LED will blink shortly, then release the button.
- NOTE: The calibration sequence may also be initiated via Modbus command

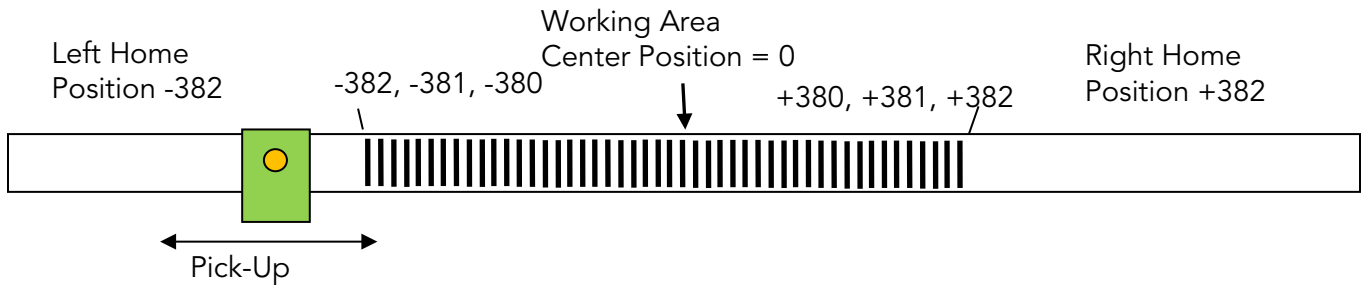

The internal procedure within the controller is as follows: The input amplifiers are being set to a known sensitivity (gain), then the laser power for each channel is adjusted until the desired internal voltage level (2V) is reached. The new power setting values are saved in EEPROM. This is the only procedure that will alter the laser power levels. During normal operation, only the input amplifier gain is adjusted for maintaining proper voltage levels.



Figure 16. Location of internal CAL button for initial optical level calibration

### 3.5.3 Indexing for Linear Absolute Position

The MR303 linear sensor system is an incremental encoder and will not know the absolute position when the unit is powered up. Generally, an index point must be provided to obtain absolute position.

Since the MR303 fiber optic sensor works different from standard encoders, it is possible to reserve a "homing" area on the film strip. Outside the actual work area, the film is left transparent without alternating lines.

After the robot powers up, the servo system must drive the sensor head either left or right to the clear "homing" area until encoder pulses are no longer received. The desired Preset reference count, corresponding to the absolute known position to the start of the first line, is loaded into the position counter. The servo motor then drives towards the start of the working area. The position counter will start counting as soon as the first line is encountered.

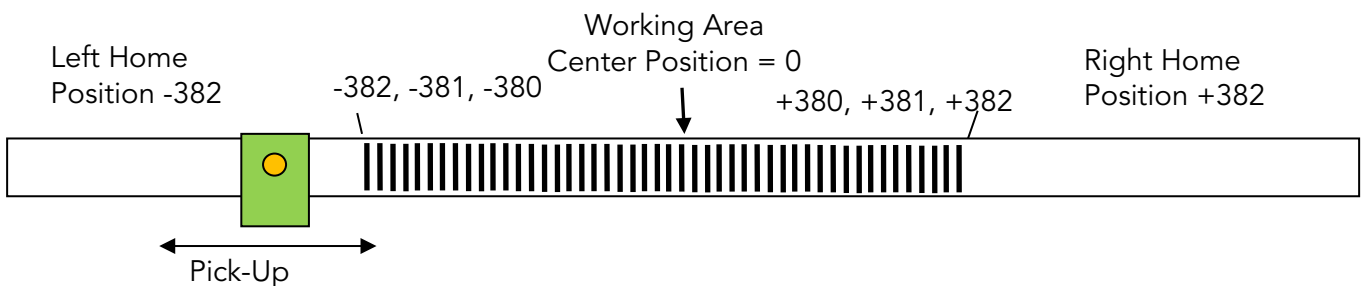

**Note:** The number examples above are when x2 multiplier is used.

The left and right homing positions are provided to the servo control system as part of an initial factory calibration cycle.

Whenever there is opportunity to position the sensor to an area outside the working area and perform a "homing" procedure, the above described scheme is elegant and does not add complexity or cost to the system.

This procedure can also be combined with an optical input sensitivity calibration sequence per Section 3.6.

## 3.6 Power-up or Periodic Optical Sensitivity Calibration

As part of the normal power-up procedure, it is possible to perform an optical power calibration. This is useful so that the system immediately starts counting with the highest accuracy. The external HOMING Input (J1-Pin 3) of the controller is configured in such a way that when a +24V signal is applied to this input, the internal counter is Reset to the Preset value stored in Register 0x209. If so configured as described herein, the input amplifier level calibration may be initiated at the same time.

### 3.6.1 Optical sensitivity calibration for linear sensors

At power up, it is recommended to move the MR303 sensor head to a clear area of the film strip and then initiate a +24V logic pulse of ~100ms to 1sec duration to the HOMING Input input (J1-Pin 3).

Instead of a +24V logic pulse on J1-15, the sequence may be initiated using Modbus FC05 0x007.

Register 0x208 must be configured to 0x03 in order for the above procedure to work properly.

This procedure can also be repeated at periodic interval or during self-test cycles.

### 3.6.2 Optical sensitivity calibration for rotary sensors

For MR30X series rotary sensors, optical sensitivity calibration is performed in real-time when the encoder is rotating. The controller monitors the signal lows and highs and sets the internal gain accordingly. Therefore, no special calibration procedure is required for rotary sensor.

## 3.7 Initial System Configuration and Power-Up Examples

This section provides examples on how the encoder system can be initially configured and operated. The three scenarios described are:

- Rotary encoder
- Linear Encoder using Film With HOMING Region
- Linear Encoder using Film without HOMING Region

Micronor supplies ZAPPY® 302 software free-of-charge to MR30X users. The software is designed for configuring and troubleshooting an MR30X rotary or linear encoder system. The ZAPPY® screens and command buttons emulate the Modbus commands so that the user can become familiar with configuring and operating the system.

For detailed information about specific Modbus commands, consult Section 7.

### 3.7.1 Rotary Encoder Configuration and Operation

Hardware Example: MR304 Rotary Encoder and MR302-2 Controller

#### For Rotary Applications Using Quadrature Outputs Only

For systems that will use the A/B quadrature outputs only, the user need only optically connect the encoder to the controller and go. Optical Signal Calibration occurs automatically while the encoder is turning.

Before initial use, it is recommended to connect the optical link (all segments, full length) first and perform an Optical Signal Calibration. This is to make sure that the optical link loss budget is within specifications.

Initial Configuration Sequence Rotary Encoder using Quadrature Outputs Only		
Step	Action	Notes
1	Connect	Connect encoder and controller with final optical link connected (all segments).
2	Optical Calibration	Perform an Optical Signal Calibration by simultaneously rotating the encoder and holding down the on-board Calibration pushbutton for at least 10 seconds. The POWER LED will blink while calibration is performed. After 10 seconds, the STATUS LED will blink shortly indicating that calibration is complete and the user can then release the button.
3	Ready To Use	

Power-Up Sequence Rotary Encoder using Quadrature Outputs Only		
Step	Action	Notes
1	System ready to operate	

### For Rotary Speed/Position Sensing Applications Using Modbus Interface

Many integrated OEM systems will want to take advantage of the embedded functions within the MR302-2 controller for reading rotary encoder speed and position via the Modbus interface. This frees the controller or PLC from tracking these parameters themselves via the quadrature outputs.

Initial Configuration Sequence Rotary Encoder using Modbus communications			
Step	Command Name	Register Address	Notes
1	Reset Mode	FC10 0x208	Set to 1 to reset Position Counter to the Preset Value. For the Position Counter to function properly, the user's actuator will need to be in the desired reference position when the ZERO Input is pulsed.
2	Preset Value	FC10 0x20A	This will be the Position Counter value when the user's actuator system is in the reference position. Typically the user will set this value to 0 unless another initial setting is required.
3	Quadrature Multiplier	FC10 0x211	Set to 0 for 2 counts per line Set to 1 for 4 counts per line
4	Direction	FC10 0x20B	With this command, the user can set the preferred direction and "polarity" of the Position Counter. Set to 0=CW or 1=CCW.
5	Speed Filter	FC10 0x216	For applications monitoring Speed via Modbus, the user may want to select a value (0-8) to filter speed results.
6	Save To EEPROM	FC05 0x002	Send this command to save all current parameters to internal EEPROM

Power-Up Sequence Rotary Encoder using Modbus communications			
Step	Command Name	Action	Notes
1	User actuator system is at initial reference position.		
2	ZERO Input	Pulse ZERO Input or send FC05 0x007 command	With Reset Mode 0x208 set to 1, the controller will reset Position Counter to the Preset Value. ZERO Input may also be a homing switch.
3	System ready. Read Position Count and Speed via Modbus		

### 3.7.2 Linear Encoder With Film And Using HOMING Function

Hardware Example: MR303 Linear Encoder, MR302-2 Controller and TD5334 series Film Strip with 1 or 2 HOMING regions. The diagram below illustrates an application employing a Film Strip with HOMING region on both sides.

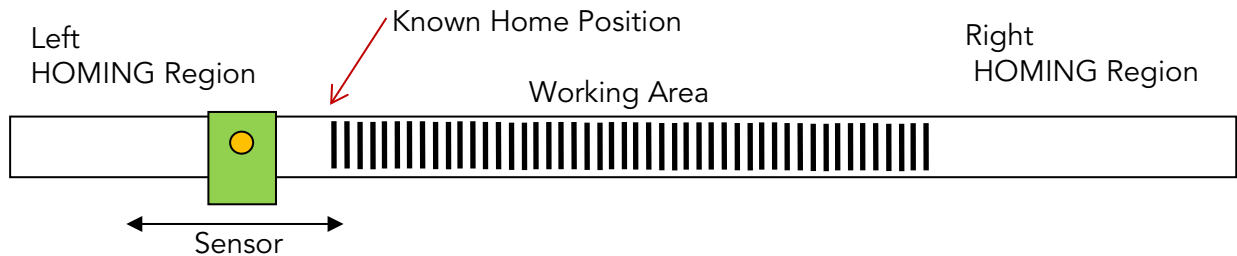

Section 3.5.3 described how to using the HOME technique as an Index for absolute position monitoring. This type of application would then use the Modbus interface to read absolute position and speed status. The quadrature outputs can also be used independently.

The following tables describe how to initially configure and operate the MR303 system in this scenario.

Initial Configuration Sequence HOMING Linear Encoder Configuration			
Step	Command Name	Register Address	Notes
1	Reset Mode	FC10 0x208	Set to 3 to perform both an Optical Signal Calibration and reset Position Counter at the same time. For the Position Counter to function properly, the user's actuator will need to be in the "Homing" zone when the ZERO Input is pulsed.
2	Preset Value	FC10 0x20A	This will be the Position Counter's initial value when the user's actuator system moves out of the HOMING region and encounters the first line on the Encoder Film Strip. Typically user will set this value to 0 unless another initial setting is required.
3	Quadrature Multiplier	FC10 0x211	Set to 0 for 2 counts per line Set to 1 for 4 counts per line
4	Direction	FC10 0x20B	With this command, the user can set the preferred direction and "polarity" of the Position Counter. Set to 0=CW or 1=CCW.
5	Speed Filter	FC10 0x216	For applications monitoring Speed via Modbus, the user may want to select a value (0-8) to filter speed results.
6	Save To EEPROM	FC05 0x002	Send this command to save all current parameters to internal EEPROM

Example:

To perform the optical calibration using the external pin and set the counter to a predefined value, and set the turn direction to 1 the initial setup should be as follows:

Register 0x0001 "xxxx" Counter Register may be any value  
 Register 0x0208 "3" Reset Mode  
 Register 0x0209 "250" Preset Register. This value will be in the counter after the reset  
 Register 0x020B "1" Turn or Count Direction  
 Execute FC05-2 to save the parameters in EEPROM

After a normal power up, all is required to drive the sensor to the transparent area of the film and pulse the External Homing input.

Register 0x0001 "250" Counter Register is now set at 250  
 Register 0x0208 "3" Reset Mode  
 Register 0x0209 "250" Preset Register. This value will be in the counter after the reset  
 Register 0x020B "1" Turn or Count Direction

Note: Executing the calibration will automatically save all current parameter register content to EEPROM.

Normal Power-Up Sequence HOMING Linear Encoder			
Step	Command Name	Action	Notes
1	User actuator system within HOMING region.		
2	ZERO Input	Pulse ZERO Input or send FC05 0x007 command	With Reset Mode 0x209=3, controller will perform Optical Signal Calibration and reset Position Counter to the Preset Value.
3	System ready. Read Position Count and Speed via Modbus. It is recommended to initiate the above procedure at any time that the sensor is known to be in the HOMING region. Quadrature outputs can also be used independently.		

### 3.7.3 Linear Encoder With Film Without HOMING Region

Hardware Example: MR303 Linear Encoder, MR302-2 Controller and TD5334 series Film Strip without HOMING region. The diagram below illustrates an application employing a Film Strip without any HOMING region.

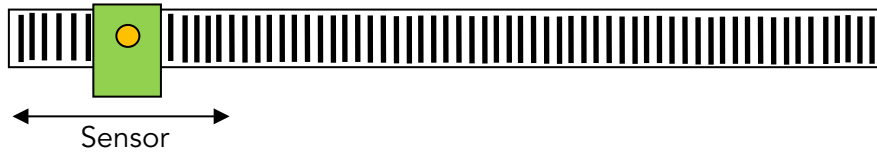

In this section, the MR303 linear encoder uses an Encoder Film Strip without a HOMING region. That is, the Encoder Film Strip is a sequence of lines only. A typical application will use the Modbus interface to track position and speed. The quadrature outputs can also be used independently.

The following tables describe how to initially configure and operate the MR303 system in this scenario.

Initial Configuration Sequence Non-HOMING Linear Encoder			
Step	Command Name	Register Address	Notes
1	Reset Mode	FC10 0x208	Set to 1 to reset Position Counter only. For the Position Counter to function properly, user's actuator must be at the reference position when ZERO Input is pulsed.
2	Preset Value	FC10 0x20A	This will be the Position Counter value when the actuator is at the reference position. Typically, the user will set this value to 0 unless another initial setting is required.
3	Quadrature Multiplier	FC10 0x211	Set to 0 for 2 counts per line Set to 1 for 4 counts per line
4	Direction	FC10 0x20B	With this command, the user can set the preferred direction of the Position Counter. Set to 0=CW or 1=CCW.
5	Speed Filter	FC10 0x216	For applications monitoring Speed via Modbus, the user may want to select a value (0-8) to filter speed results.
6	Save To EEPROM	FC05 0x002	Send this command to save all current parameters to internal EEPROM
7	Optical Calibration		Perform an Optical Signal Calibration by simultaneously moving the Encoder Film Strip back and forth while holding down the on-board Calibration pushbutton for at least 10 seconds. The POWER LED will blink while calibration is performed. After 10 seconds, the STATUS LED will blink shortly indicating that calibration is complete and the user can then release the button.

Power-Up Sequence Non-HOMING Linear Encoder			
Step	Command Name	Action	Notes
1			User actuator system is at initial reference position.
2	ZERO Input	Pulse ZERO Input or send FC05 0x007 command	Controller will reset Position Counter to the Preset Value.
3			System ready. Read Position Count and Speed via Modbus Quadrature outputs can also be used independently.
4			An automatic Optical Calibration is performed whenever the sensor sweeps through the active area at minimum speed of 0.2 meters/second.

## 4. Modbus Serial Communications

### 4.1 Modbus Serial Interface

The main purpose of the Modbus-compatible serial interface is to query the controller for status, position and speed while in operation. The serial interface is also used to configure the controller unit as well as system troubleshooting.

MICRONOR supplies the ZAPPY® software to access these functions via the USB or RS232 serial interface of your PC (Personal Computer) computer.

#### Serial Interface Specification (default)

- Serial with logic levels full duplex.
- Baudrate programmable: 57,600 baud
- 1 Start Bit
- 8 Data Bits
- 1 Stop Bit
- no parity

The protocol is Modbus compatible and thus the protocol includes a node address. That is so that the PCB could be integrated into larger systems using a number of Modbus slaves. Factory Standard ModBus Address is set to 235 (Hexadecimal 0xEB).

Note: The MR302-1 Controller requires a RS485/422-to-RS232 converter for interfacing to the RS232 COM Port of a computer.

Note: The MR302-1 Controller uses the 235 address as the common call address. It will always respond to address 235.

#### Pull-Up/Pull-Down Resistors

Since the bus lines will go idle and into an undefined state when inactive, it is important that the lines are pulled-up and pulled-down respectively when inactive.

The pull-up / pull-down resistor are typically at the master. Consult following Modbus circuit definitions.

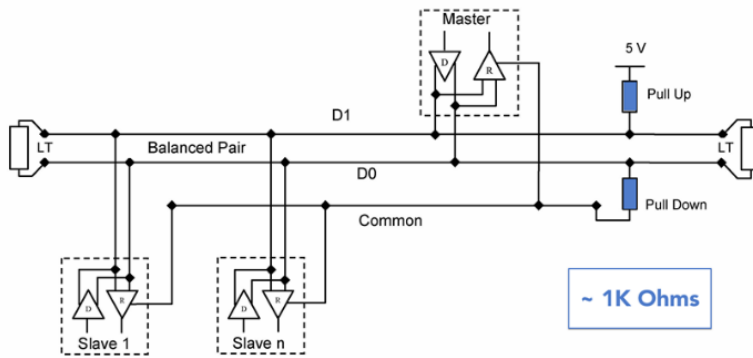

**2-Wire Circuit  
Half Duplex**

D1 (RX+ / TX+) is pulled up to +5V

D0 (RX- / TX-) is pulled down to GND

Recommended resistor is 1KΩ

**2W-MODBUS Circuits Definition**

Required Circuits		For device	Required on device	EIA/TIA-485 name	Description
on ITr	on IDv				
D1	D1	I/O	X	B/B'	Transceiver terminal 1, V1 Voltage ( V1 > V0 for binary 1 [OFF] state )
D0	D0	I/O	X	A/A'	Transceiver terminal 0, V0 Voltage ( V0 > V1 for binary 0 [ON] state )
Common	Common	--	X	C/C'	Signal and optional Power Supply Common

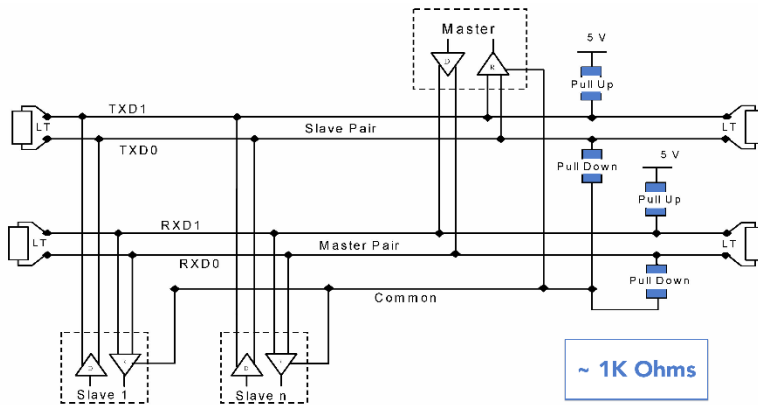

**4-Wire Circuit  
Full Duplex**

TXD1 (TX+) and RXD1 (Rx+) are pulled up to +5V

TXD0 (TX-) and RXD0 (RX-) are pulled down to GND

Recommended resistor is 1KΩ

**4W-MODBUS Circuits Definition**

Required Circuits		For device	Required on device	EIA/TIA-485 name	Description for IDv
on ITr	on IDv				
TXD1	TXD1	Out	X	B	Generator terminal 1, Vb Voltage ( Vb > Va for binary 1 [OFF] state )
TXD0	TXD0	Out	X	A	Generator terminal 0, Va Voltage ( Va > Vb for binary 0 [ON] state )
RXD1	RXD1	In	(1)	B'	Receiver terminal 1, Vb' Voltage ( Vb' > Va' for binary 1 [OFF] state )
RXD0	RXD0	In	(1)	A'	Receiver terminal 0, Va' Voltage ( Va' > Vb' for binary 0 [ON] state )
Common	Common	--	X	C/C'	Signal and optional Power Supply Common

## 4.2 MODBUS Communications Protocol

The communications protocol follows the Modbus RTU (binary) protocol. A number of commands allow for configuring the operational parameters of the MR302 while other commands are specifically meant for diagnostics used during setup, maintenance and troubleshooting. The status and position readout registers are intentionally arranged in sequence for a quick readout while system is in operation mode. The format for the commands and responses in general follow the MODBUS RTU specification, with the exception that not all registers maybe combined within one readout sequence. See table below for allowable register combination.

→ Modbus information can be obtained at [www.modbus.com](http://www.modbus.com)

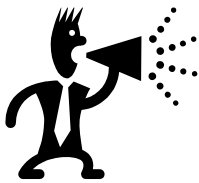

### What Is ZAPPY® Setup Software?

Zappy® 302 is a setup program provided free-of-charge with the purchase of the MR302 system. ZAPPY® runs on Windows XP, Vista, Windows 7, Windows 8 and requires .net Framework 4.0 to be on the machine. Please refer to section 7 for detailed information.

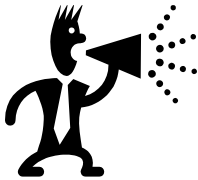

Unless you plan to connect the MR302 to your own PLC or computer equipment for real-time data retrieval, you do not need to become familiar with the detailed communications protocol described herein.

### Framing

Message frames are separated by a silent interval of at least 3.5 character times. If a silent interval of more than 1.5 character times occurs between two characters of the message frame, the message frame is considered incomplete and is discarded.

A 16bit LRC/CRC Frame Check follows the message.

### Device Address Selection

The MR302 comes pre-configured with Device address 235 (Broadcast address).

The MR302 always listens to address 235 (Broadcast Address). To re-program the device address, send desired new address via command FC10 to register 0x104 via the broadcast address (235) and then send the appropriate "STORE EEPROM" command via FC52 register. Upon that procedure the unit will listen to both the newly assigned Device Address *and* the Broadcast address 235.

### Register Numbers versus Meter Addresses

In this instruction manual, all registers are referred to by their address, i.e. starting at 0.

Some Master devices (e.g., Modicon) require that the desired Register Number and not the Register Address be entered. The Register Number is 1 higher than the Register Address. For entry to these devices, add 1 to the Register Address shown in the tables below. The Register Address shown will then be output from these devices.

FUNCTION FC03 – Read Holding Registers  
 FUNCTION FC10 – Write Holding Registers

Holding registers FC03 are used for reading the position and all other parameters  
 These Registers can be written using Function FC10 using identical address offset

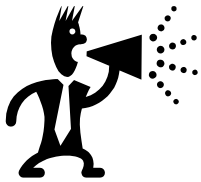

Be cautious of using the Operating Mode 0x105 register command. Do not put unit in any of these modes without first consulting the user manual. Be familiar with what these functions before using.

Register Address	Register Number	Name	# regs	Range	Description
0x000	0x001	System Status	1	n/a	Returns the system status. A 0x0000 means all is ok. See status information.
0x001	0x002	Get Encoder Count	2	n/a	Returns or sets position count as a 32-bit integer.
0x003	0x004	Get Speed	2	n/a	Returns the speed information as a 32-bit signed in 1/100 rpm.
0x004	0x005	reserved	2	n/a	
0x040	0x041	Get Error Counts	18	n/a	Returns 18 registers with the total number of errors for each error class.
0x100	0x101	reserved	2	0 - MaxCount	
0x104	0x105	Device Address	1	1 – 254	Sets the MR302 serial address for commands. Note that the address 4 cannot be used. A FC06 command to save EEPROM must be issued following this command.
0x105	0x106	Operating Mode	1	0, 2	Used to setting MR302 in calibration, or troubleshooting mode. Normal Operating is 0. Debug mode is 2. Do not put unit in any of these modes without first consulting the user manual. Be familiar with what these functions before using.

0x130	0x131	CHA Amplitude minimum	1	n/a	Outputs the minimum observed amplitude of the optical signal. Generally this signal is less than 15 counts because the optical signal should swing from 0 to 640counts. (0V to 2V). Of course the encoder must be turning otherwise the signal can be anything from 0 to +640.
0x131	0x132	CHA Amplitude maximum	1	n/a	Outputs the maximum observed amplitude of the optical signal. Generally this is signal approximately 640 counts because the optical signal should swing from 0 to 640counts. (0V to 2V). Of course the encoder must be turning otherwise the signal can be anything from 0 to +640.
0x132	0x133	Voltage Offset Factory Calibration	1	-128 – 127	Factory use only – do NOT write to it. Hardware calibration value for voltage output
0x133	0x134	Voltage Gain Pos Factory Calibration	1	-128 – 127	Factory use only – do NOT write to it. Hardware calibration value for voltage output
0x134	0x135	Voltage Gain Neg Factory Calibration	1	--128 – 127	Factory use only – do NOT write to it. Hardware calibration value for voltage output
0x135	0x136	Current Gain Factory Calibration	1	-128 – 127	Factory use only – do NOT write to it. Hardware calibration value for current output
0x136	0x137	CHB Amplitude minimum	1	n/a	Outputs the minimum observed amplitude of the optical signal. Generally this signal is less than 15 counts because the optical signal should swing from 0 to 640counts. (0V to 2V). Of course the encoder must be turning otherwise the signal can be anything from 0 to +640.
0x137	0x138	CHB Amplitude maximum	1	n/a	Outputs the maximum observed amplitude of the optical signal. Generally this signal is approximately 640 counts because the optical signal should swing from 0 to 640counts. (0V to 2V).

					Of course the encoder must be turning otherwise the signal can be anything from 0 to +640.
0x138	0x139	VCSEL Control	1	0 - 3	Factory use only – do NOT write to it. Used to turn OFF the optical output for each channel. → 1 = CHA → 2 = CHB → 3 = Both
0x139	0x13A	Baudrate Serial Communications	1	0 – 3	Sets the Baudrate for Serial Communications on the MODBUS. 0 = 9,600 1 = 19,200 2 = 38,400 3 = 57,600 4 = 115,200
0x13A	0x13B	Internal 3.3V value	1	n/a	Gets the internal voltage in 10mV increments.
0x13B	0x13C	Power Supply 5V	1	n/a	Gets the 5V power supply voltage in 10mV increments.
0x13C	0x13D	reserved	1	n/a	
0x13D	0x13E	reserved	1	n/a	
0x13E	0x13F	reserved	1	n/a	
0x140	0x141	Amplifier Gain CHA	1	0 – 255	Controls the gain of Channel A amplifier. 0 is max gain, 255 is minimum gain
0x141	0x142	Amplifier Offset CHA	1	0 – 255	Controls the input offset of Channel A amplifier. This is set at the factory only. Should typically be a low number of less than 20.
0x142	0x143	Amplifier Gain CHB	1	0 – 255	Controls the gain of Channel B amplifier. 0 is max gain, 255 is minimum gain
0x143	0x144	Amplifier Offset CHB	1	0 – 255	Controls the input offset of Channel B amplifier. This is set at the factory only. Should typically be a low number of less than 20.
0x144	0x145	Optical output Power for CHA	1	0 – 255	Controls the output power of CHA. 0 is minimum power, 255 is maximum power. It is used to balance each VCSEL diode. Power output may also be increased to compensate for long fiber optic link losses.
0x145	0x144	Optical output Power for CHB	1	0 – 255	Controls the output power of CHB.

					0 is minimum power, 255 is maximum power. It is used to balance each VCSEL diode. Power output may also be increased to compensate for long fiber optic link losses.
0x200	0x201	Voltage Mode	1	0 - 3	Defines the output mode for the voltage output. 0 = OFF no Position Output
0x201	0x202	Voltage Scale	2	0 – MaxCount	Establishes the scale used for the voltage output. Regardless of Voltage Mode setting 10V refers to the scale value. When the position count reaches the scale value the output is 10V.
0x203	0x204	Voltage Filter	1	0 – 15	Sets the low pass filter for the voltage output.
0x204	0x205	Current Mode	1	0 – 2	Defines the output mode for the current output. 0 = OFF current is < 300uA.
0x205	0x206	Current Scale	2	0 – MaxCount	Establishes the scale used for the isolated current output. Regardless of current Mode setting 16mA refers to the scale value. When position count reaches the scale value then the output is 16mA plus 4mA bias for a total of 20mA.
0x207	0x208	Current Filter	1	0 – 15	Sets the low pass filter for the current output.
0x208	0x209	Reset Mode	1	0 – 4	Defines how the hardware ZERO input resets the internal counter. 0 = No action when external input is high. 1 = Resets the Position Counter. 2 = Initiate an Optical Calibration when high 4 = Initiate an Laser Calibration when high  The above bit positions may be combined. Example: 3 = Resets Position Counter <i>and</i> initiates an Optical Calibration Cycle. This is useful when using film strip with clear homing area.
0x209	0x20A	Preset Value	2	0 - MaxCount	Counter will be preset to this value when the Zero push button is pressed

					or when hardware input is activated. (See Reset Mode)
0x20B	0x20C	Direction	1	0 - 1	Defines output results based on turning direction of the sensor 0 = when CW outputs are positive reading. 1 = when CCW then outputs are positive reading
0x211	0x212	Quadrature Signal Multiplier	1	0,1	0 = counts cycles x2 1 = counts cycles x4
0x214	0x213	Quadrature Voltage	1	0,1	Set the line driver output voltage 0 = disabled 1 = 5V 2 = 12V 3 = 24V
0x215	0x216	Analog Output Select	1	0,1	Select voltage or current output 0 = Voltage 1 = Current (4-20mA with 3mA overrange)
0x216	0x217	Speed Filter	1	0 - 8	Sets the speed filter. Applies to ModBus and USB output. The higher the number the stronger the filter effect. 0 disables the filter.
0x230	0x231	Set Point 1 On	2	0 - MaxCount	Lower threshold for digital limit switch output 1
0x232	0x233	Set Point 1 Off	2	0 - MaxCount	Upper threshold for digital limit switch output 1
0x234	0x235	Set Point 2 On	2	0 - MaxCount	Lower threshold for digital limit switch output 2
0x236	0x237	Set Point 2 Off	2	0 - MaxCount	Upper threshold for digital limit switch output 2
0x238	0x239	Talker Rate/Mode	1	0 - 4095	Directs the unit to output the position or speed at the pre-programmed interval. <b>Not implemented</b>
0x300	0x301	CHA minimum	1	n/a	engineering measurement output
0x301	0x302	CHA maximum	1	n/a	engineering measurement output
0x302	0x303	CHB minimum	1	n/a	engineering measurement output
0x303	0x304	CHB maximum	1	n/a	engineering measurement output
0x304	0x305	n/a	1	n/a	engineering measurement output
0x305	0x306	n/a		n/a	
0x306	0x307	n/a		n/a	
0x307	0x308	n/a		n/a	
0x330	0x331	POT 1A	1	0 - 255	Pot U4A (CHA offset) (ENGWRT only)
0x331	0x332	POT 1B	1	0 - 255	Pot U4B (CHA gain) (ENGWRT only)

0x332	0x333	POT 1C	1	0 - 255	Pot U4C (CHB offset) (ENGWRT only)
0x333	0x334	POT 1D	1	0 - 255	Pot U4D (CHB offset) (ENGWRT only)
0x400	0x401	Device Name	4	n/a	Returns the ASCII string equivalent as device name (MR330)
0x404	0x405	Version	4	n/a	Returns the ASCII string equivalent of the software version form MM.mm.bb
0x408	0x409	Serial Number	2	n/a	Returns the serial number of the device.

**Note:** MaxCount =  $2^{25}-1 \Rightarrow 33,554,431$

**FUNCTION FC05 – Write Single Coil**

Single Coil commands are used to trigger an action by sending True (0xFF)

Register Address	Register Number	Name	Description
0x001	0x002	Device Reset	Same as a Power OFF and Power ON cycle.
0x002	0x003	Save To EEPROM	Save current parameters to EEPROM. A time delay of approximately 20ms should be allowed before sending any other command.
0x003	0x004	Restore From EEPROM	Restore all configuration parameters from EEPROM. Same as a Power Up.
0x004	0x005	Restore Factory Defaults	Restores Factory Defaults for each user parameter. Factory calibration values and pairing data are not affected.
0x005	0x006	Clear Status	Clears the status register. If another error is pending then the status register will reflect that new value in queue.
0x006	0x007	Clear Error Count Table	Resets error table counters to 0. Same as in power up.
0x007	0x008	Emulate ZERO Input	This software emulates external ZERO input pulse whose response is determined by the Reset Mode 0x208 setting.

**MODBUS Message Format**

The following is a brief overview of the detailed byte by byte messaging of the ModBus protocol. Please consult the Modbus standards for more detailed information. When using appropriate drivers the user does not need to be concerned with the details as described below.

- |                       |                    |                      |
|-----------------------|--------------------|----------------------|
| DA = Device Address   | DD = Data to read  | CRCL = CRC Byte low  |
| FC = Function Code    | WW = Data to write | CRCH = CRC byte high |
| RA = Register Address | SF = Sub Function  |                      |
| NR = Number to Read   | EC = Error Code    |                      |
| NB = Number of bytes  |                    |                      |

FC	Action	Sync 3.5b	Byte Number										
			1	2	3	4	5	6	7	8	9	10	11
01	request	pause	DA	FC	RA								
01	response		DA	FC	NR								
03	request	pause	DA	FC	RA	RA	NR	NR	CRL	CRH			
03	response		DA	FC	NB	DD*	DD*	CRL	CRH				
04	request	pause	DA	FC	RA								
04	response		DA	FC	NR								
05	request	pause	DA	FC	RA								
05	response		DA	FC	RA								
08	request	pause	DA	FC	SF								
08	response		DA	FC	SF								
23	request	pause	DA	FC	RA	RA							
23	response		DA	FC	NR								

DD\* = number of bytes requested or being sent

### 4.3 Detailed Description of Each Function

This section describes the physical outputs from the encoder monitoring circuit.

#### 4.3.1 Counter (Register 0x001)

Register Address: 0x001  
 Register Count: 2

This is an internal summing counter that keeps accurate track of the full number of quadrature cycles and the multiplier as applied to in register 0x211. The counter is relative to a given starting position. The user may reset or preset the counter to any value within a full 32 bit range.

Range is: signed 32bit

The (-) sign bit indicates that the encoder is turning Counter Clockwise CCW (looking at the encoder from the shaft end)  
 The encoder Counter is volatile and will be reset once electrical power is lost.

MODBUS commands:

Address	Register	Description	Access
0x001	2	Encoder Count	Read / Write

#### 4.3.2 Speed /RPM output (Register 0x003)

Register Address: 0x003  
 Register Count: 2

Speed is calculated based on measuring the time for one quadrature cycle period. Measuring the period provides very accurate yet fast update rates at slow encoder speeds. The update rate is always 1ms.

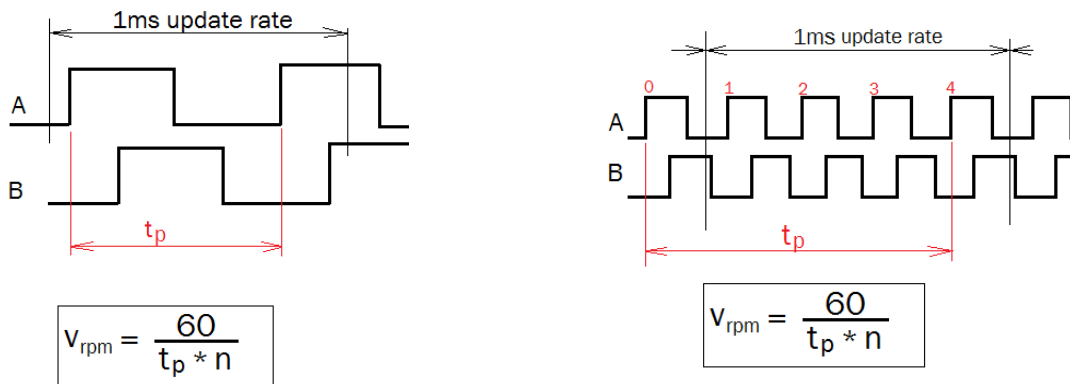

When the encoder rotates slower than 1 period per millisecond, the speed can only be updated whenever one period has elapsed. At high speeds the measurement is a combination of number of counts and the exact time these counts occurred during the past millisecond.

Output Format: The output is in RPM x 100 (12012 -> 120.12RPM)

Range: Lowest RPM is 0.33 and highest is 60,000

Accuracy: 1% (quartz crystal controlled)

Resolution: 0.01 RPM regardless of scale

MODBUS commands:

Address	Register	Description	Access
0x003	2	Encoder Speed	Read - Only

### 4.3.3 Voltage Mode (Register 0x200)

Register Address: 0x200

The setting of the mode determines how the speed in rpm or position count will be output as analog voltage to the voltage output.

Default: Mode 0

SPEED Modes	Description
0	<p>Output corresponds to actual RPM where CCW rotation is negative voltage.                      The voltage output range is 0V to +10V when the encoder rotates CW. Overrange extends ~ 0.4V beyond 10V                      The voltage output range is 0V to -10V when the encoder rotates CCW. Overrange extends ~ 0.4V beyond 10V.</p> <p style="text-align: center;"><b>Voltage Speed Mode 0</b></p>
1	<p>Output corresponds to the absolute value of the RPM, regardless of the direction.                      The output is always from 0V to +10V regardless of direction of rotation. Over range extends ~0.4V beyond 10V</p>

	<p style="text-align: center;"><b>Voltage Speed Mode 1</b></p>
<b>POSITION Modes</b>	<b>Description</b>
2	<p>The output ranges from 0V to +10V (overrange +0.4V) for CW motion with +10V corresponding to the Voltage Scale setting (Register 24).                  The output ranges from 0V to -10V (overrange -0.4V) for CCW motion with -10V corresponding to the Voltage Scale setting (Register 24).</p> <p style="text-align: center;"><b>Voltage Position Mode 2</b></p>

#### 4.3.4 Voltage Scale (Register 0x201)

Register Address: 0x201

The voltage scale can be set by the user to track SPEED or POSITION.

Example: With Voltage Mode set to 0, a Voltage Scale setting of 1000 will provide a full scale +10V output for 1000RPM (CW) or -1000V output for 1000RPM (CCW). Faster speeds will linearly extend from ±10V until peaking at approx. 10.4V.

Range	Description
10-100,000 (SPEED)	In SPEED mode a Voltage Scale setting of X establishes ±10V “full scale” value to correspond to X RPM.
1-28,388,607 (POSITION)	In POSITION mode, a Voltage Scale setting of X establishes ±10V “full scale” output to correspond to X Counter value.

### 4.3.5 Voltage Filter (Register 0x203)

Register Address: 0x203

A user configurable low pass filter exists to allow smoothing of the calculated RPM based on user constants. It is the filtered RPM that is output to the voltage DAC. The 3dB filter point is programmable from 500Hz (no filtering) down to 1Hz

$$A_f = \frac{(A_{f[t-1]} * 2^n - 1) + A_{m[t]}}{2^n}$$

$A_f$  : Filtered analog output value  
 $A_{f[t-1]}$  : Previous filtered analog output value  
 $n$  : filter constant in  $2^n$  milliseconds  
 $A_m$  : new analog (unfiltered) value

☞ The analog output is updated every 1ms thus when setting the filter value to  $n$  an approximate time constant of  $n$  ms can be expected. The MR320 measures the period between passing slits of the code wheel. When the encoder is turning slow so that the elapsed time between slits is larger than 1ms then the low pass algorithm is changed and the time constant becomes larger as the encoder turns slower. This adaptive filtering algorithm provides for a smooth output signal change.

☞ If no filtering is desired, simply turn the filter OFF by setting it to value 0.

☞ When in position mode, it is recommended not to use the filter.

MODBUS commands:

Address	Register	Description	Access
0x200	1	Voltage Mode	Read/Write
0x201	2	Voltage Scale	Read/Write
0x203	1	Voltage Filter	Read/Write

4.3.6 Current Mode (Register 0x204)

Register Address: 0x204

The scalable current output provides filtered RPM or POSITION analog output depending upon the chosen mode.

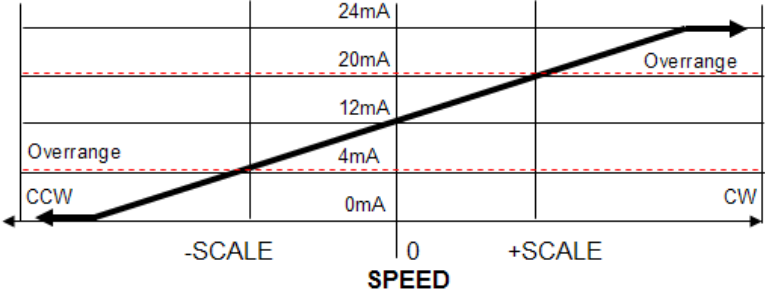
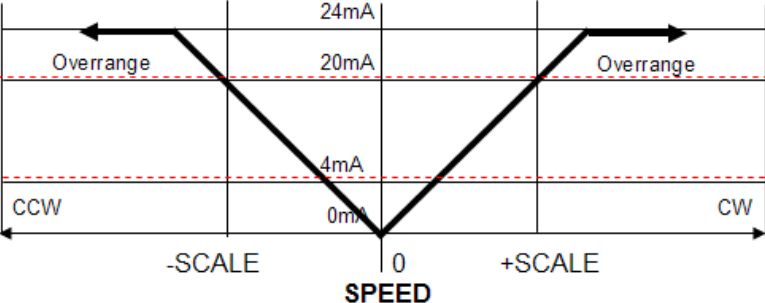
SPEED Modes	Description
0	<p>Bipolar output over 4mA to 12mA to 20mA where 12mA is equal to 0 RPM.                      CW rotation from 0RPM to (Current Scale) RPM corresponds to 12mA to 20mA. Overrange extends from 20mA to 23mA (maximum)                      CCW rotation from 0RPM to (Current Scale) RPM corresponds to 12mA to 4mA. Overrange extends from 4mA to 0mA (minimum).</p> <p style="text-align: center;"><b>Current Speed Mode 0</b></p> 
1	<p>Unipolar output range of 0-24mA where 0mA represents 0RPM, regardless of direction.</p> <p style="text-align: center;"><b>Current Speed Mode 1</b></p> 
2	<p>Unipolar output range of 4-20mA where 4mA represents 0RPM, regardless of direction.</p>

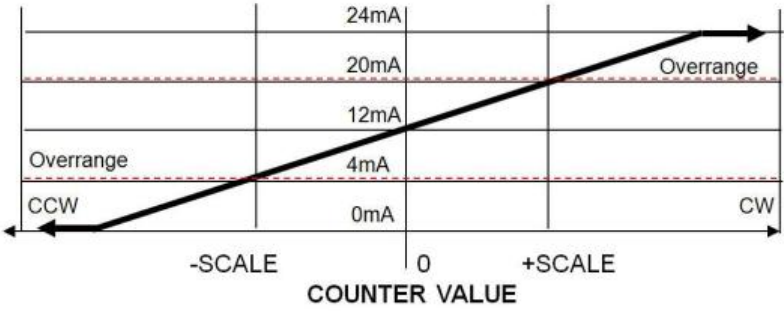
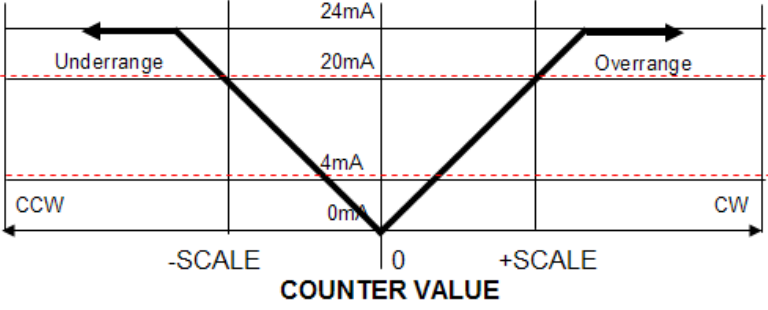
POSITION Modes	Description
3	<p>Bipolar output over 0mA to 12mA to 20mA where 12mA is equal to the zero position/counter value.                      CW rotation from 0 counter value to Current Scale setting corresponds to 12mA to 20mA. Overrange extends from 20mA to 23mA (maximum)                      CCW rotation from 0 counter value to negative Current Scale setting corresponds to 12mA to 4mA. Overrange extends from 4mA to 0mA (minimum).</p> <p style="text-align: center;"><b>Current Position Mode 3</b></p> 
4	<p>Unipolar output range of 0-24mA representing the absolute value of the Counter. 0mA represents the zero position and 20mA corresponds to the Current Scale setting (regardless of direction or sign).                      Overrange extends from 20 23mA (maximum).</p> <p style="text-align: center;"><b>Current Position Mode 4</b></p> 

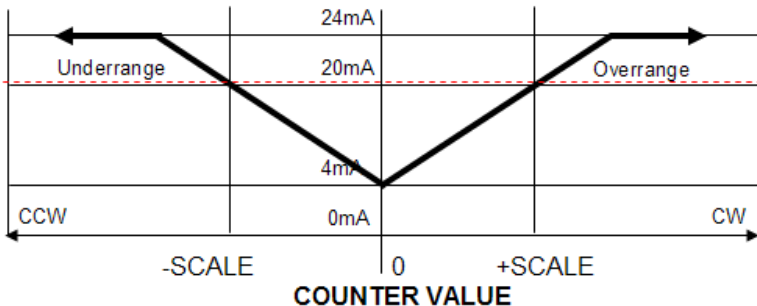
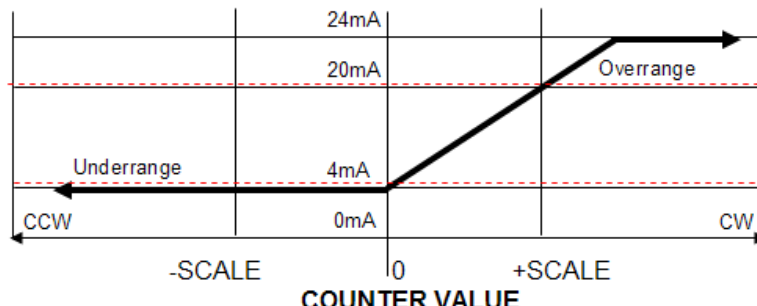
<p>5</p>	<p>Unipolar output range of 4-24mA representing the absolute value of the Counter. 4mA represents the zero position and 20mA corresponds to the Current Scale setting (regardless of direction or sign). Overrange extends over 20-23mA range.</p> <p style="text-align: center;"><b>Current Position Mode 5</b></p> 
<p>6</p>	<p>Window mode with Output range of 4-24mA. 4mA represents zero and negative position and 20mA corresponds to Current Scale. Overrange extends over 20-23mA.</p> <p style="text-align: center;"><b>Current Position Mode 6</b></p> 

In all cases there is an overrange capability of 4mA to 23mA.  
Use the MODE command to select the desired output mode.

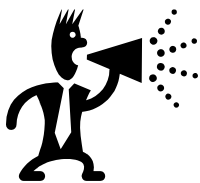

*Current Output Cautions...*

- Current outputs are inherently short circuit proof!
- The maximum burden resistance for the MR302 is 500 Ohm with a +24V power supply. At 23mA that represents a voltage drop of 12V.
- To minimize internal heat dissipation we recommend that the user inserts a 'burden resistance' to always assure at least 200 Ohm.

### 4.3.7 Current Scale (Register 0x205)

Register Address: 0x205

Default: 1000 RPM/full range.

Range	Description
0	The value 0 turns this function OFF. This may be useful when the encoder is expected to operate at high speeds and the voltage output is not required. Disabling this function leaves processor resources for other functions such as the quadrature divider. It is recommended to disable the output when it is not required.
10-10,000 (SPEED)	In SPEED mode (Register 204), a Current Scale setting of X establishes 20mA as "full scale" output corresponding to X RPM.
1-8,388,607 (POSITION)	In a POSITION mode (Register 204), a Current Scale setting of X establishes 20mA as the "full scale" output when the Counter value reaches X.

### 4.3.8 Current Filter (Register 0x207)

Register Address: 0x207

A user configurable low pass filter exists to allow smoothing of the calculated RPM based on user constants. It is the filtered RPM that is output to the voltage DAC. The 3dB filter point is programmable from 500Hz (no filtering) down to 1Hz

$$A_f = \frac{(A_{f[t-1]} * 2^{n-1}) + A_{m[t]}}{2^n}$$

A<sub>f</sub> : Filtered analog output value

A<sub>f</sub> [t-1] : Previous filtered analog output value

n : Filter constant in 2nmilliseconds

A<sub>m</sub> : new analog (unfiltered) value

☞ The output is updated every 1.0ms thus when setting the filter value to n an approximate time constant of 2n ms can be expected. The MR302 measures the period between passing slits of the code wheel. When the encoder is turning slow so that the elapsed time between slits is larger than 1ms then the low pass algorithm is changed and the time constant becomes larger as the encoder turns slower. This adaptive filtering algorithm provides for a smooth output signal change at low rpm.

☞ If no filtering is desired simply turn the filter OFF by setting it to value 0.

☞ When in position mode it is recommended not to use filtering.

MODBUS commands:

Address	Register	Description	Access
0x204	1	Current Mode	Read/Write
0x205	2	Current Scale	Read/Write
0x207	1	Current Filter	Read/Write

#### 4.3.9 Counter Reset Mode (Register 0x208)

Register Address: 0x208

The internal Position Counter may be reset by applying a +24V signal to the Counter RESET Input located on pin 3 of J1.

This input assumes different functions depending on the setting as described below:

The register value is binary coded:

Bit 0 = Reset Counter to the Preset value stored in parameter 0x209

Bit 1 = Activate Optical Calibration when input goes high

Bit 2 = Activates Transmitter Balancing when input is raised high

The bits are logically OR'd and all or none of the above functions apply when the external input goes high/

Modes	Description
000b	No action with rising edge of external input
001b	RESET encoder counter to Preset value stored in parameter 0x209
011b	Reset encoder counter and initiate a calibration cycle. This maybe a useful function in conjunction with a linear filmstrip encoder. When the sensor is at a known position in the homing area of the film strip. The counter can be set to a known position value and at the same time the optical amplitude is adjusted.

MODBUS commands:

Address	Register	Description	Access
0x208	1	Reset Mode	Read / Write

### 4.3.10 Counter Reset (Register 0x209)

Register Address: 0x209

The internal Position Counter will be preset to this pre-programmed value whenever the External Hardware Reset input goes from logic 0 to logic 1. Sometimes this function is also called "homing". The value is 32bit signed.

**HARDWARE RESET VALUE Mode**  
 (Example shown uses Current Position Mode 6  
 Where R (RESET Value) = 1/2 of Current Scale Value)

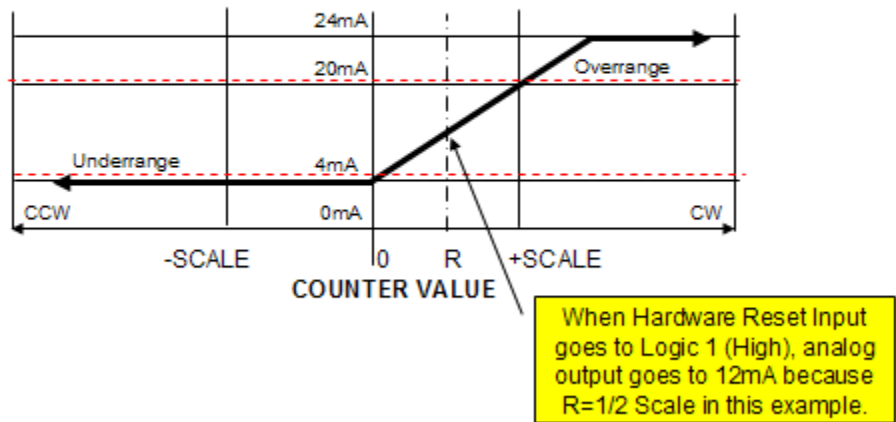

MODBUS commands:

Address	Register	Description	Access
0x209	2	Reset Value	Read / Write

### 4.3.11 Quadrature Edge Multiplier (Register 0x211)

Register Address: 0x211

The internal position counter can be set to advance with each edge on the channel A signals x2 or advance on all transitions x4. If an encoder has a resolution of 512ppr then a total of 512 x 4 = 2048 counts are available.

Modes	Description
0	X2 counting
1	X4 counting

☞ Be sure to set the output scaling according to the multiplier selected.

- ☞ Due to the inner workings of the MR302 firmware, the controller can only be set to x2 or x4 multiplication.
- ☞ This setting will NOT affect speed calculation.

MODBUS commands:

Address	Register	Description	Access
0x211	1	Count Multiplier	Read / Write

#### 4.3.12 Turn Direction (Register 0x20B)

Register Address: 0x20B

This parameter defines the encoder's rotational direction. When this parameter is set to "0" (default) all outputs follow the right-hand rule convention. When the encoder turns clockwise then the speed indication is positive and the position counter increments. Analog outputs follow accordingly: i.e. a positive speed is indicated by a positive voltage.

When this direction parameter is set to "1", then all directional outputs are reversed. This may become useful when an encoder cannot be installed to turn in the CW direction within a system definition for CW being positive speed or positive position.

Modes	Description
0	Analog outputs and digital read-out follow CW direction
1	Analog outputs and digital read-out are reversed from normal CW direction

- ☞ Quadrature outputs A&B are not affected by this parameter setting. The user must assure proper wiring to achieve the desired direction of an externally connected device.

MODBUS commands:

Address	Register	Description	Access
0x20B	1	Direction	Read / Write

### 4.3.13 Line Driver Output Voltage (Register 0x214)

Register Address: 0x214

This parameter defines the output voltage level of the complementary line driver outputs. The output voltage should be adjusted to the receiving device such as a VFD drive or similar.

- 0 = Outputs disabled
- 1 = 5V (typical 3.3V)
- 2 = 12V (typical 10.5V)
- 3 = 24V (Power Supply – 1.5V)

MODBUS commands:

Address	Register	Description	Access
0x214	1	Line Driver Voltage	Read / Write

### 4.3.14 Analog Output Select (Register 0x215)

Register Address: 0x215

T

he analog output on J1 is either a voltage or a current 4-20mA output. This parameter selects which mode the output will operate at.

- 0 = Voltage Output
- 1 = Current 4-20mA Output

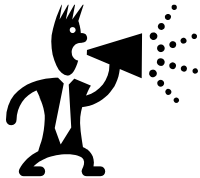

**CAUTION**

Connecting a voltage source to this output be sure to set this parameter to current output. Otherwise the voltage output will attempt to drive against the applied voltage source.

☞ This parameter is protected and the unit must be set to Op-Mode 2 in order to affect this setting.

MODBUS commands:

Address	Register	Description	Access
0x215	1	Analog output Selection	Read / Write

#### 4.3.15 EEPROM SET (FC05-2)

##### Function Call FC05-2

Parameters are not automatically saved to EEPROM. The user must issue a special command to commit the parameters to EEPROM. It is highly advisable to always initiate an EEPROM commit otherwise all the stored parameters will be lost when power is removed to the MR302 unit.

In addition to checksums, all parameters are stored twice internally and when retrieved both copies are compared and only restored when there is a match or when it is determined that there is one good copy of the parameter.

To store parameters into the EEPROM initiate Modbus command FC5-2

☞ All parameters in EEPROM are always restored at power up. There is no special user interaction required to read parameters from the EEPROM.

## 4.4 Error Handling and Troubleshooting

### 4.4.1 Explanation of Status and Error Handling

The MR302 incorporates a sophisticated integrity monitoring, error and failure reporting system. There are four Error Groups:

1. EEPROM  
At start-up the EEPROM checksum and EEPROM data integrity are checked.
2. Power Supply Voltages  
At start-up, the applied power supply voltage (+5V) and internal voltages are checked. If they fall outside the required value, errors are logged and reported. These voltages are evaluated once at system power-up. Subsequent voltage changes will not be evaluated.
3. Sensor Read Error
  - Low optical power
  - Position read error
  - Restore value out of range
4. Communication Errors  
Communication errors are flagged by the underlying Modbus drivers. However, Modbus standard does not specify a data integrity test. This is where the MR302 allows the user to query the Status byte after each transmission to verify if the provided data was within the appropriate range, etc.

### 4.4.2 Explanation of Status and Error Indication

When an error occurs the System Status Word is set with the associated Error Code (Register 0x00). When more than one error at the time occurs then the error code is stacked up in order of its priority.

Each error has an associated error counter. The user may request all error registers for examination through a request to Register 0x040. MODBUS Function Register 0x40, Reads all 18 Error Registers Sequentially

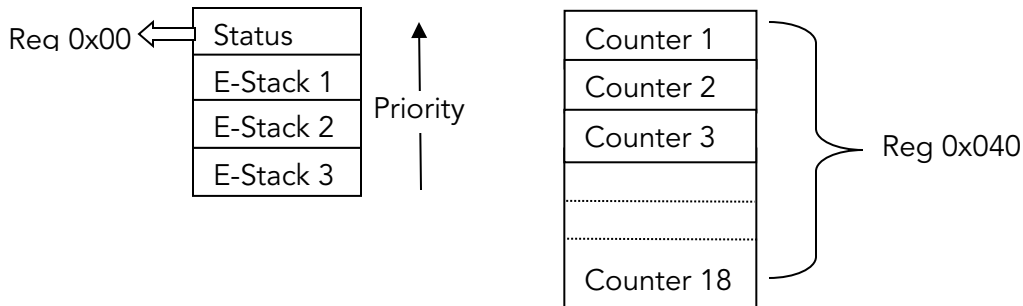

Error Groups

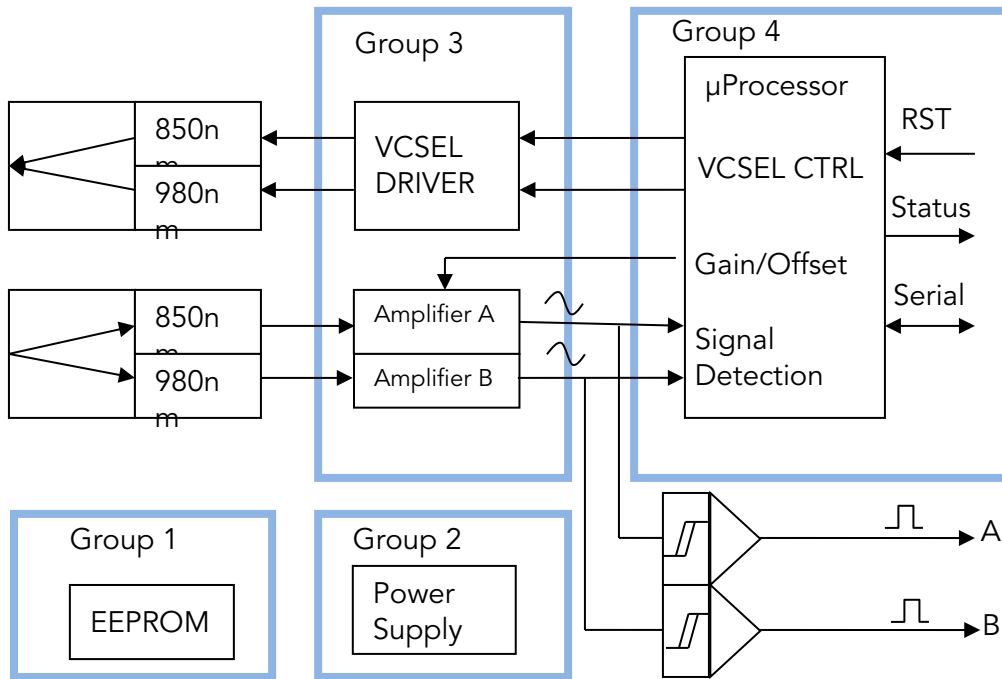

All errors get logged but may not necessarily provide visual indication. The user should take necessary action based on the severity level of the reported status/error.

- 3 = System will no longer work without a remedy.
- 2 = Important, problem should be fixed but system may still be partially operational
- 1 = Benign, system keeps on working

After examination the user may clear the Error Indication by issuing the Function Call FC5 to coil number 5. This will clear the indicated error in the Status byte. If there are more errors stacked up, then the next highest priority will be displayed.

Some errors are cleared as soon as normal operation is established. For instance, when the sensor is disconnected or a high loss in the optical connection occurs, an error is reported and the PWR LED will blink. When the optical connection is re-established, then the error will clear itself without user interaction.

Some errors are not sufficient cause of a problem. They are logged and indicated by a short blink on the PWR LED and then will clear themselves. For instance, if the 5V power supply deviates by more than  $\pm 5\%$ , an error is indicated. Since the MR302-2 works flawlessly in the range of 4.3V to 5.6V, there is no cause for further error indication.

Table 1. Error Codes

Hardware Related Status Indication					
EEPROM					
#	Description	S	Remedy	How Cleared	Announced
257	EEPROM INIT EEPROM is not initialized not initialized. This occurs only on first factory power up of new system or when a badly corrupt EEPROM is detected	3	Firmware automatically re-initializes the EEPROM. User must remove power and apply power again. Restore factory values. All parameters are lost.	Recycle Power	Blink 5x + code
258	EEPROM Checksum checksum failure both banks	3	Both data banks indicate a bad checksum. User should read all parameters and verify proper settings and then save parameters again using Miconor ZAPPY® software.	software or recycle Power	Blink 5x + code
259	EEPROM Checksum Low Bank checksum failure low bank	1	One set of data in EEPROM shows a bad checksum. Firmware automatically corrects the error.	n/a	n/a
260	EEPROM Checksum High Bank checksum failure low bank	1	One set of data in EEPROM shows a bad checksum. Firmware automatically corrects the error.	n/a	n/a
261	EEPROM Bad Value One or more parameter values are out of range in both data banks.	3	User should use ZAPPY® to read and examine the data and restore the corrupted value.	Timed Clear	Blink 5x + code
Voltages					
#	Description	S	Remedy	How Cleared	Announced
513	Bad Hardware No Clock Signal from CPLD Bad I2C Bus on internal components	3	Recycle Power If persist repair	next startup	Blink 5x
514	3.3V out of range	3	Check 5V input power	next startup	Blink 5x
515	5V out of range	2	Check 5V input power	next startup	Blink 4x + Code

Position Sensor Failures					
#	Description	S	Remedy	How Cleared	Announced
770	Sensor Disconnect Detect low optical power	3	Check Fiber Optic connection to the sensor. Initiate a new Sensor pairing.	self clear when restored.	Blink 3x + code
771	Sensor Low Power The fiber is connected however not enough power is being received for reliable operation.	2	this error occurs due to contaminated connectors. Or long link lengths in excess of 1.5km. Check your fiber optic link. The one way loss should be less than 5dB.	self clear examine error counter for a history of this error.	Blink 2x + code
772	Receiver gets excessive optical power	2	If this occurs the VCSEL optical power needs to be reduced. This is accomplished using ZAPPY® software. An optical attenuator could also be inserted into the fiber optic line.	self clear examine error counter for a history of this error.	Blink 1x once
773	Calibration Operation	3	This is not an error! Indicats number of automatic calibration cycles have been performed.	Self clear	none

Communication Failures					
#	Description	S	Remedy	How Cleared	Announced
1025	CMD Unknown Function A non-valid or non-implemented ModBus function was sent to the controller	1	Check your software for correct function calls.	self clear after one blink	Blink 1x once
1026	CMD Unknown Register A non implemented register address was addressed	1	Check your software for correct register addressing. See user manual with address table.	self clear after one blink	Blink 1x once
1027	CMD Wrong Register Count The register count in your command did not match the length of requested register.	1	Check your software for correct register addressing. See user manual with address table. <b>Note:</b> This controller does not allow to read across multiple registers.	self clear after one blink	Blink 1x once
1028	CMD Wrong Device Addr. The device address sent was not matching the address of this unit.	1	The MR330 controller has on fixed address at 235. If you are not sure what the address is talk to the unit at 235 and reset your desired bus address.	self clear after one blink	Blink 1x once
1029	CMD Wrong Value The data value was outside the permissible range for this parameter.	1	Consult the user instruction for the permissible parameter values allowed in each register.	self clear after one blink	Blink 1x once
1030	CMD Checksum ModBus Packet Checksum was invalid.	1	Resend the packet.	self clear after one blink	Blink 1x once

### 4.4.3 Reading The Error Counters

The entire packet of all 18 error counters may be read by issuing MODBUS command to Register 0x040 with a register count of 18. The sequence of registers is according to the error number in Table 1 in ascending order.

Each register is a 16-bit word. If the most significant bit is set to a logical one, this indicates that there is an active error residing in the Status stack.

The remaining 15 bits indicate the number of errors that occurred since power was applied to the unit.

The user may clear all error counters by issuing Function Call FC5 coil #6.

## 5. Warranty Information

### Warranty

MICRONOR INC. warrants this product to be free from defects in material and workmanship for a period of 1 (one) year from date of shipment. During the warranty period we will, at our option, either repair or replace any product that proves to be defective.

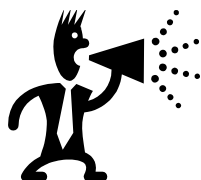

Applying improper supply voltage ( $5V \pm 10\%$ ) voids warranty.

To exercise this warranty, write or call your local MICRONOR inc. representative, or contact MICRONOR INC. headquarters. You will be given prompt assistance and return instructions. Send the instrument, transportation prepaid, to the indicated service facility. Repairs will be made and the instrument returned transportation prepaid. Repaired products are warranted for the balance of the original warranty period, or at least 90 days.

### Limitations of Warranty

This warranty does not apply to defects resulting from unauthorized modification or misuse of any product or part. This warranty also does not apply to Fiber Optic Connector interfaces, fuses or AC line cords. This warranty is in lieu of all other warranties, expressed or implied, including any implied warranty of merchantability of fitness for a particular use. MICRONOR INC. shall not be liable for any indirect, special or consequent damages.

### Contact Information:

Micronor Inc.  
900 Calle Plano, Unit K  
Camarillo, CA 91320  
USA

T +1-805-389-6600  
F +1-805-389-6605  
Email [support@micronor.com](mailto:support@micronor.com)  
URL [www.micronor.com](http://www.micronor.com)

### For Europe:

Micronor AG  
Pumpwerkstrasse 32  
CH-8015 Regensdorf  
SWITZERLAND

T +41-44-843-4020  
F +41-44-843-4039  
Email [support@micronor.com](mailto:support@micronor.com)  
URL [www.micronor.ch](http://www.micronor.ch)

## 6. Specifications

### 6.1 MR302-1 DIN Rail Mount Controller

Electrical Interface	Note: All electrical connections shall not exceed 3 meters
Connector	10-pin Screw Terminal, 30-14 AWG Phoenix Mating Plug 1803659, supplied with Controller
Quadrature Outputs	Quadrature A+/A-/B+/B- User Selectable Level: 5V, 12V, 24V Bandwidth: 100 kHz maximum
Discrete Digital Interface	HOMING Input (+24V level)
Serial Digital Interface	USB via Type B receptacle Modbus/RS485 via IEEE 1394 receptacle
Analog Output	User Settable with supplied ZAPPY® 302 software
Current Output Load Accuracy	Range=0-24mA Max burden resistance=500Ω (24V Supply) 0.25% of Full Scale (±50μA)
Voltage Output Load Accuracy	Range=±10V Max current=5mA (2kΩ load), Short circuit<5s 0.25% of Full Scale (±25mV)
Power Supply	+24 VDC ±5% , 50mA typical During power-up, external power supply shall be capable of 100mA inrush current.

Optical Interface	Specification
Connector	LC Duplex, PC Polish
Fiber Type	Duplex 62.5/125μm 0.275NA OM1 Multimode Fiber
Maximum Link Loss	Maximum 12dB round trip
Operating Wavelength	850nm (for purposes of fiber link loss calculation)
Optical Output Power	< 0dBm (1mW) average (VCSEL diodes)
Laser Safety Classification	Class 1

Physical	Specification
Mounting	35mm DIN Rail
Size	114 x 89 x 32 mm (4.5 x 3.5 x 1.25 inches)
Weight	260 g (9 oz)

Environmental	Specification
Temperature/Humidity	-5°C to +55°C (+23°F to +131°F)
Humidity	0% to 95% RH (non-condensing)
Ingress Protection	IP50

*Specifications subject to change without notice*

## 6.2 MR303 Linear Sensor

Specifications for the sensor are listed for reference purposes only. Please consult separate data sheet for current information.

Position Measurement		
Description	Specification	Notes
Resolution	100µm	Dependent on film. Contact factory for specific requirements.
Maximum Speed	>100kHz	40m/sec

Optical Interface	Specification
Connector	LC Duplex, PC Polish
Fiber Type	Duplex 62.5/125µm 0.275NA OM1 Multimode Fiber
Pigtail Length	1.5 to 10m
Maximum Link Loss	Consult Controller specifications

Physical		
Materials	Acetal, Ceramic, Glass	No ferromagnetic metals or conductive materials are used.
Dimension	30 x 28 x 15mm	1.18 x 1.10 x 0.59 inches
Weight	10g (0.3oz)	Without cable. Cable weight ~ 10g/m

Environmental	
Operating Temperature	-10° to +65°C
Storage Temperature	-25° to +70°C
Humidity	0% to 95% RH, non-condensing
Ingress Protection	IP30 (keep free from contaminants)

*Specifications subject to change without notice*

### 6.3 MR304 Rotary Sensor

Specifications for the sensor are listed for reference purposes only. Please consult separate data sheet for current information.

Measurement - No Electronic Limitations		
Description	Specification	Notes
Resolution	256, 360, 512ppr	Pulses per revolution
Maximum RPM	25,000	Mechanical limit

Optical Interface	
Connector	Specification
Connector	LC Duplex, PC Polish
Fiber Type	Duplex 62.5/125µm 0.275NA OM1 Multimode Fiber
Pigtail Length	1.5 to 10m
Maximum Link Loss	Consult Controller specifications

Physical		
Materials	Anodized aluminum housing Stainless steel shaft and bearings	
Dimension	Main Body, Ø24.9 x 38mm (Ø0.98 x 1.5 inches)	
Weight	50g (1.8oz)	With 3m pigtail Cable weight ~ 10g/m

Environmental		
Operating Temperature	-40° to +80°C	Continuous
Storage Temperature	-40° to +80°C	
Humidity	0% to 95% RH (non-condensing)	
Ingress Protection	IP40	

*Specifications subject to change without notice*

## 7. ZAPPY® 302 SOFTWARE

Micronor provides ZAPPY® 302 with the MR302-2 Controller Module. ZAPPY® for MR302 runs on: **Windows 8**, Windows 7, Vista, or XP with SP3 and with .net Framework 4.0 installed. Zappy® is used for diagnostics and troubleshooting in case the unit appears not to work properly. Zappy® is also useful for the engineer to become familiar with the controller board.

Note: The controller utilizes RS485/RS422 type signals not directly RS-232 compatible. A suitable signal translator is required.

If the PC has no Serial interface, a suitable USB to RS485/RS422 serial interface may be utilized. Sections 7.1 and 7.2 illustrate two examples using USB-to-RS422/485 Converter.

### 7.1 How To Install and Use Zappy® 302

1. Install ZAPPY® on your PC.
2. Start ZAPPY® and typically it will automatically find the MR302 PCB if properly connected to the serial interface.
3. ZAPPY® will open up to the System Functions screen as shown in Figure 14.

When parameter(s) are changed and you want to keep them saved in the PCB, you must click the "Set EEPROM" button.

Observe caution when changing serial interface parameters. The change will only take effect after a power-up boot. However, it is important that you remember what parameters were set, otherwise communication will no longer be possible with the unit.

### 7.2 ZAPPY® Menu Screens

#### 7.2.1 System Functions screen

Figure 14 shows example of System Functions screen.

In this screen, the user can set Device Address, observe system status and error conditions.

When all parameter settings have been set (including User and Service Functions), the user should execute SET EPROM to update Controller operating parameters stored in EEPROM.

The Error Register log can be very helpful in determining when the controller board is not functioning properly.



### 7.2.2 User Functions screen

Figure 15 shows example of User Functions screen.

In the User Functions screen, buttons are provided to read from and write to the various Controller registers. These buttons emulate the corresponding Modbus commands. Here, the user can actively operate the encoder system and observe system status – Position Counter, Speed, etc.

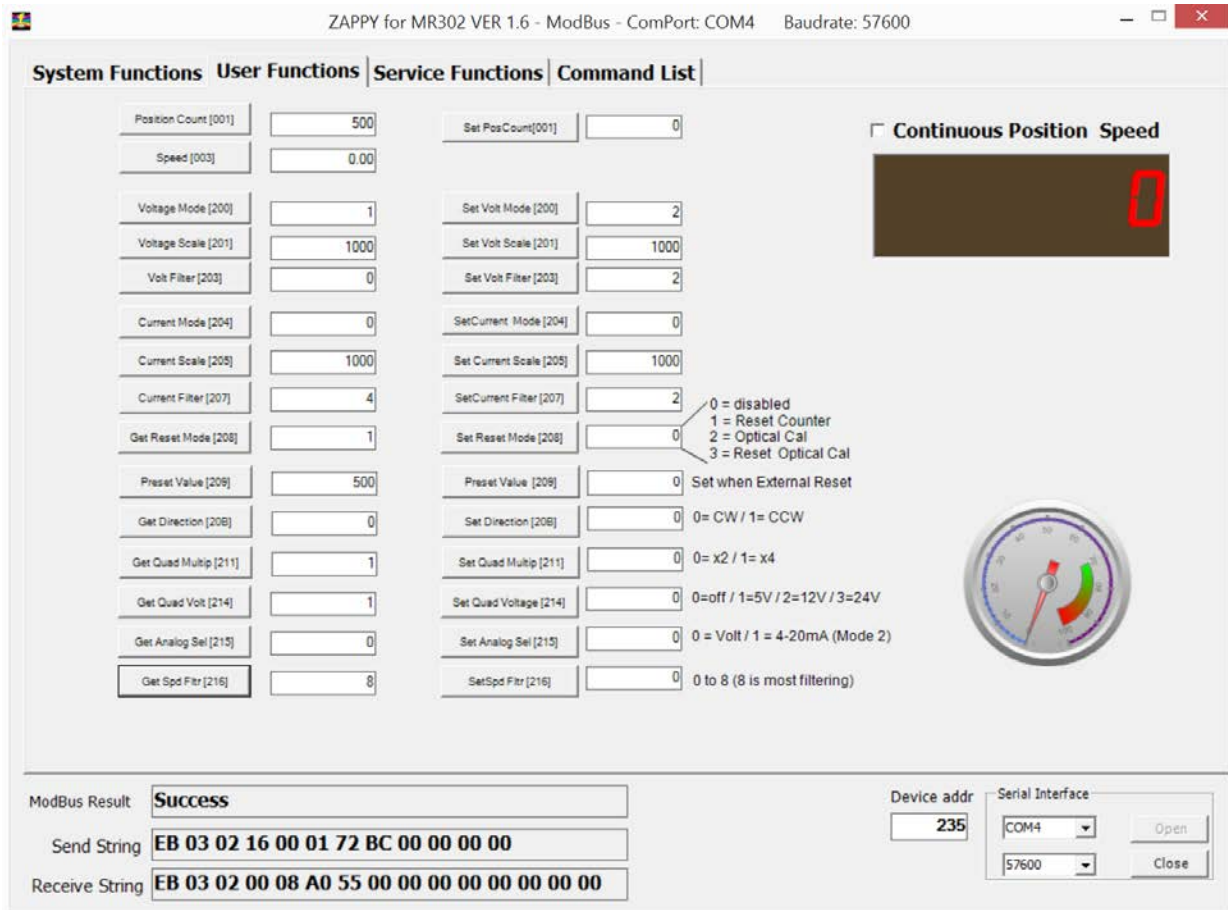

Figure 18. ZAPPY® User Functions screen

### 7.2.3 Service Functions screen

Figure 16 shows example of the Service Functions screen.

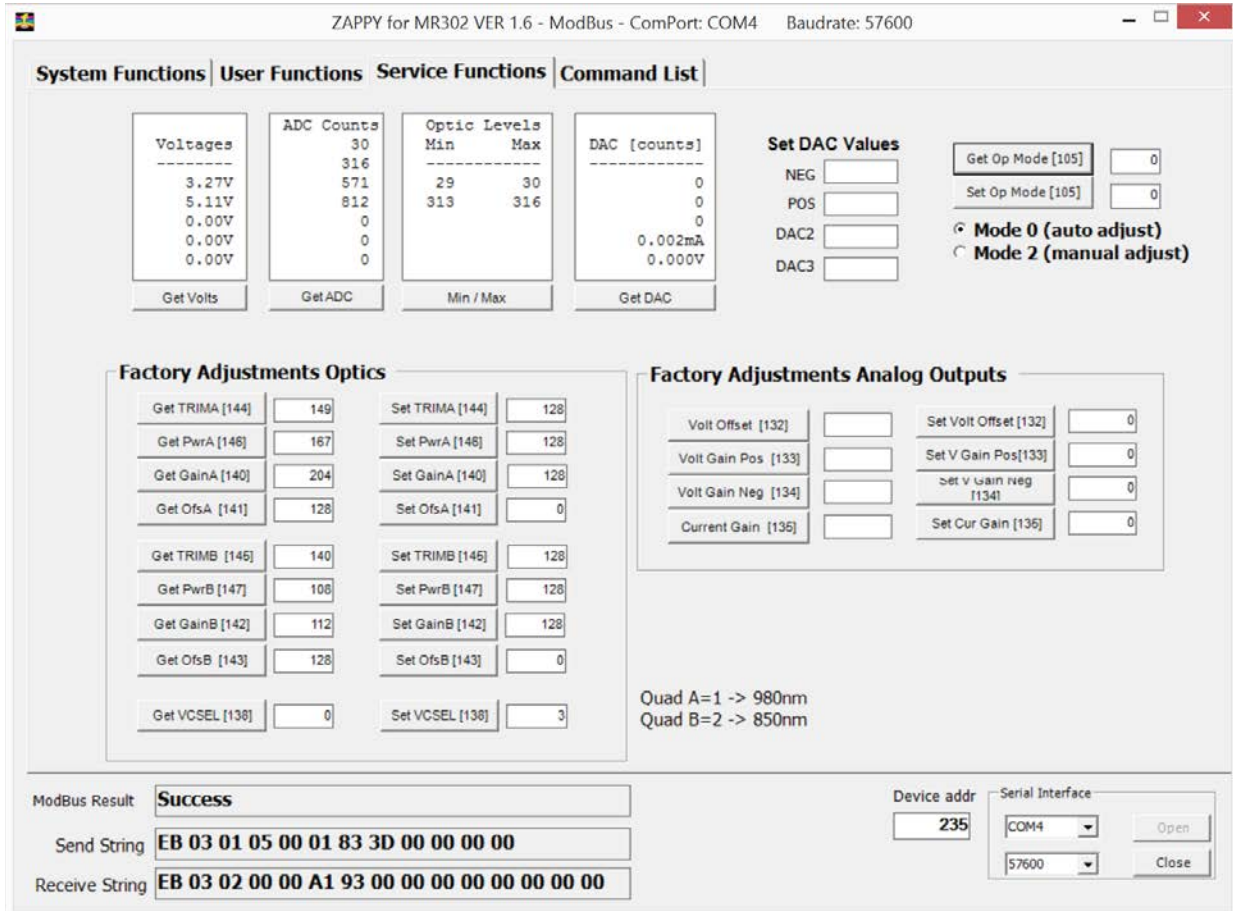
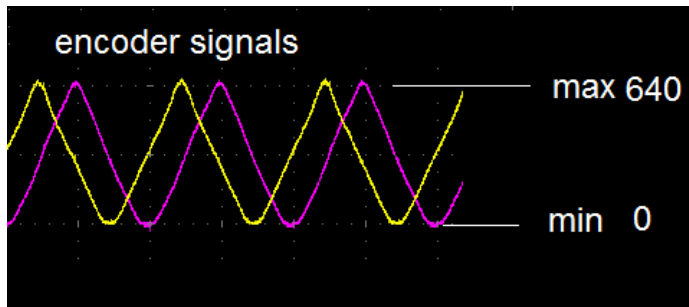

Figure 19. ZAPPY® Service Functions screen

The Service Functions page allows the user to observe inner workings of the unit. “Get ADC” readings shows the user what the analog optical signal levels are.



The minimum and maximum voltage level for each channel are given. The built-in A/D converter is 10-bit and referenced to 3.3V. The voltage can be calculated  $V = 3.3V * (Count / 1024)$ . Hence, 640 counts equals 2.06V. The peak level of the encoder signal is regulated to be 2V or 640 counts.

### 7.2.4 Command List screen

Figure 17 shows example of the Command List screen.

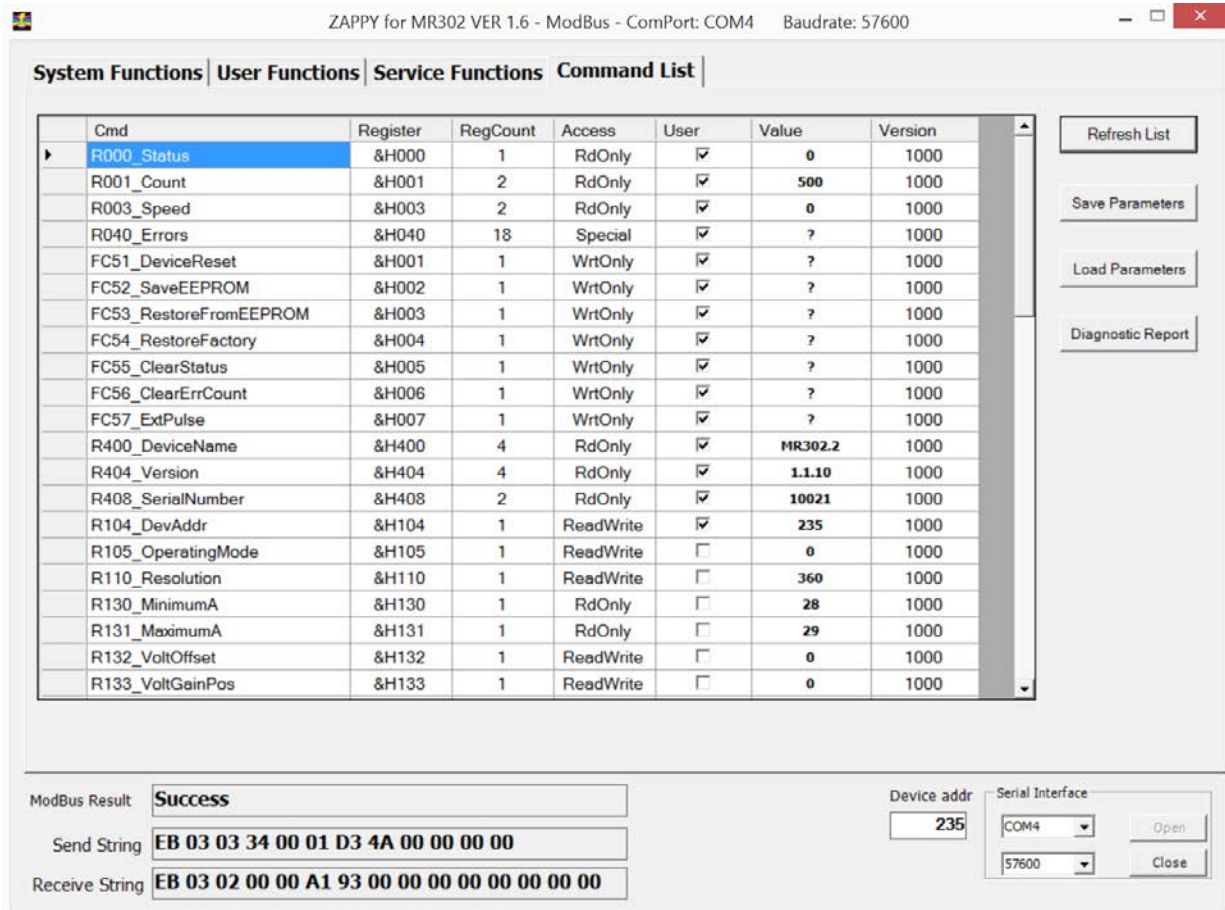

Figure 20. ZAPPY® Command List screen

The Command List page lets the user see all the commands available and their settings programmed in the controller. This is helpful when writing interface software.

It also lets the user <save> and <load> given set of parameters so that all controllers can be programmed with the same set of parameters.

When discussing issues with the factory, it is recommended to save a Diagnostics Report file and send to the factory. This will speed up the trouble shooting process for the factory engineer.

When outputting a Dagnostics Report, please assure the encoder is running at some nominal speed.

## 8. MR302 Theory of Operation

In this section, we explain the inner workings of the MR30X incremental encoder system.

The system incorporates an all-optical design per Micronor’s US Patent 7,196,320. There are no electronics in the sensor whatsoever.

The controller sends light of two distinct different colors through the transmit fiber. Within the sensor the two colors are split up into two distinct collimated light beams. Each beam passes through a spatial filter probing the A and he B track on the sensor wheel. The light of each beam is now modulated with the 90° phase shift based on the turning direction of sensor wheel. The modulated light is coupled back into the optical receive fiber guiding the light back to the receiver in the controller module.

The two colors of light are returned to the controller, converted back into an electrical signal, amplified to a known level, and then output as A/B quadrature signals.

Fiber optics will guide the light efficiently and over large distances. However the light amplitude is not guaranteed to stay stable at all. The microprocessor main role is to supervise the optical power levels and make the necessary adjustments when the light levels drift.

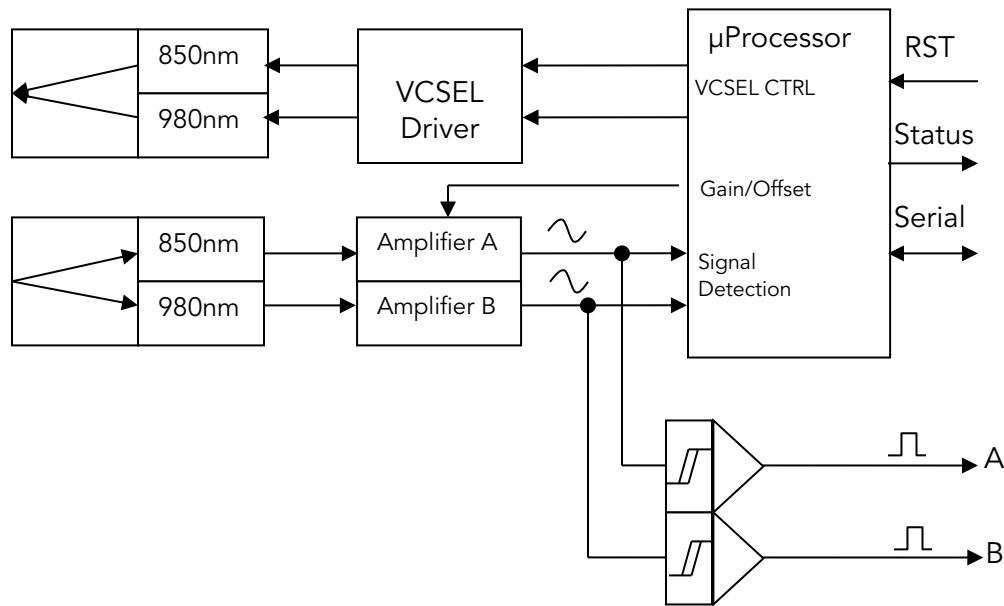
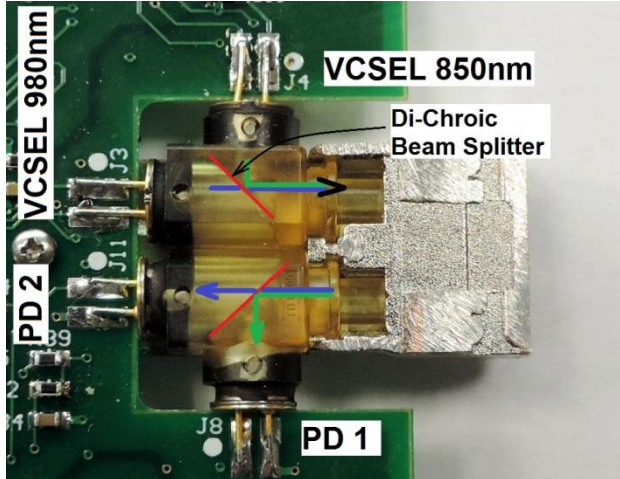

Figure 21. Block Diagram of MR302 Controller

Two light beams are generated by two VCSEL diodes, emitting at 850nm and 980nm. The light of the two VCSEL diodes is combined using an optical dichroic beam splitter. The two wavelengths are guided by the optical fiber as parallel information.



Since VCSEL (Vertical Cavity Surface Emitting Laser) diodes are indeed laser diodes, they must be electronically stabilized. In the block diagram, this is depicted within the "VCSEL Driver" block. A small portion of the emitted light is measured with an integral photodiode. The photodiode current is stabilized to a constant value. Thus, a constant optical output is maintained.

The micro controller has full control over the ON/OFF state and the power level of the VCSEL diodes. During manufacturing, the optical power level is calibrated to the

desired value. Within ZAPPY® software this level is accessible via Modbus commands 0x144 and 0x145.

The receiver is comprised of a dichroic beam splitter which separates the two wavelengths. The light of each wavelength is converted into an electrical current by photo diode 1 and photo diode 2.

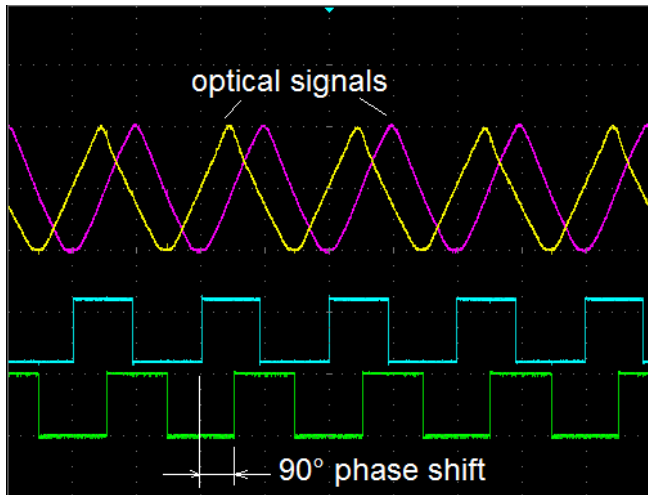

The sensor modulates the light accurately. The scope picture shows the optical analog signal following a triangular shape as the encoder disk is blocking the beam gradually.

The lower two scope traces show the quadrature output after passing through the Schmitt trigger circuit.

The microprocessor main function is to supervise the incoming optical signal, regulate the amplitude and perform other plausibility tests. Based on these tests status codes of various types are generated.

## 9. MR302 -1 Reprogramming the Firmware

Over time as the firmware functionality is expanded, it may become necessary to reprogram the firmware. The firmware resides in permanent flash memory which can be re-programmed with the appropriate software.

Download from the Micronor web site:

- REFLASH-MR302
  - Install this software on your PC.

Request from Micronor or the authorized Service representative the new Firmware:

- MR302-DIN\_V1pxpx.hex

**Note:** Only controllers with Firmware Version 1.1.22 or higher are capable of being reflashed.

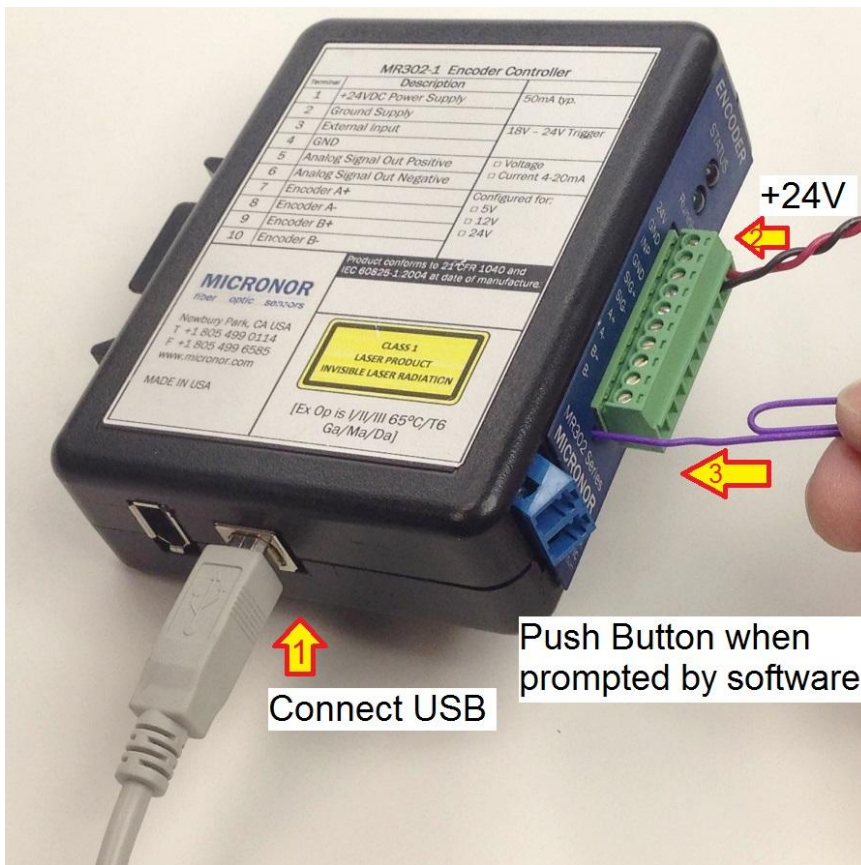

Setup the MR302-1 as shown to the left.

Connect the USB cable to the PC.

Power the unit with a suitable 24V DC supply.

Prepare a paper clip or a small pin able to reach the reset button on the MR302-1 unit.

Disconnect sensor from Unit

 Connect USB

Push Button when prompted by software

MR302 - Firmware Updater (Rev. 1.00)

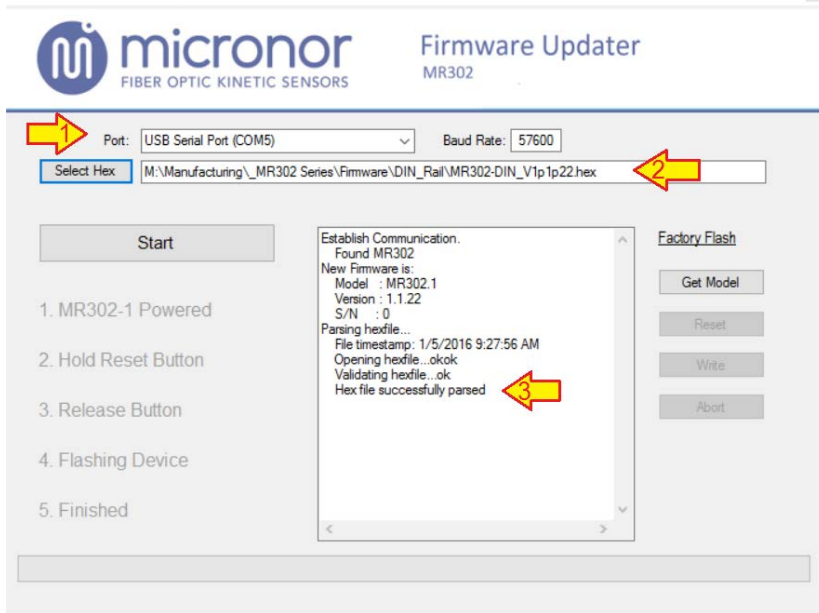

After starting the software define the Virtual Comport that the PC assigns when the USB is connected.

Select the firmware hex-file that previously was stored on your PCB.

The software validates the integrity of the hex file.

**Caution:** Make sure it is the hex-file provided to you by Micronor. It is possible to flash any valid hex-file. However at that point the MR302-1 unit will no longer be functional and may take internal damage.

MR302 - Firmware Updater (Rev. 1.00)

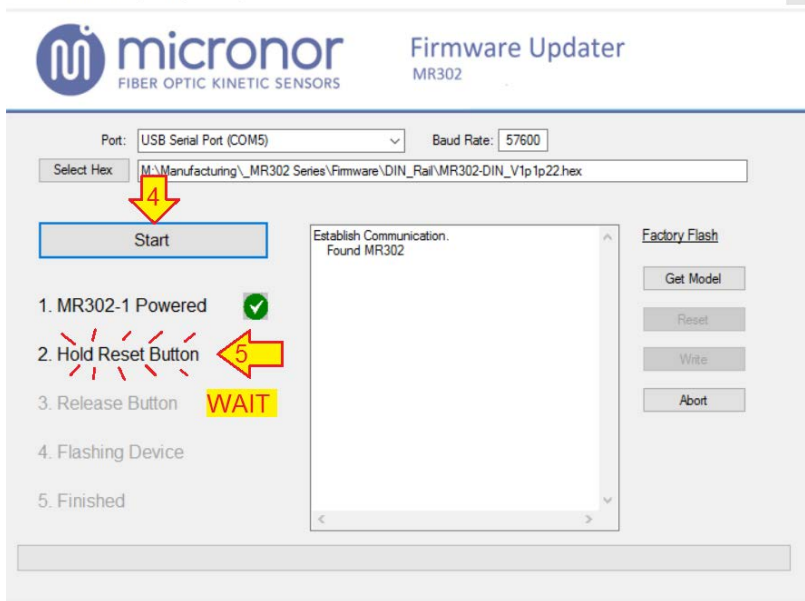

Click Start.

If connection to the MR302-1 unit has been successfully established then the software prompts to push & hold the reset button on the MR302-1 unit. Push the button and hold until the Release button prompts you to release the button.

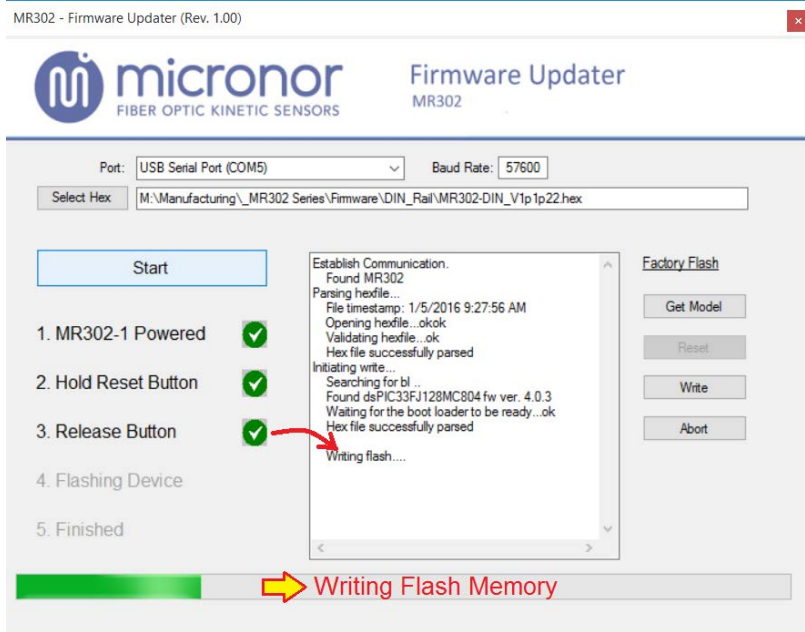

Upon release of the button the firmware is being transmitted and written to the Flash Memory of the MR302-1 unit.

The green progress bar indicates the writing progress.

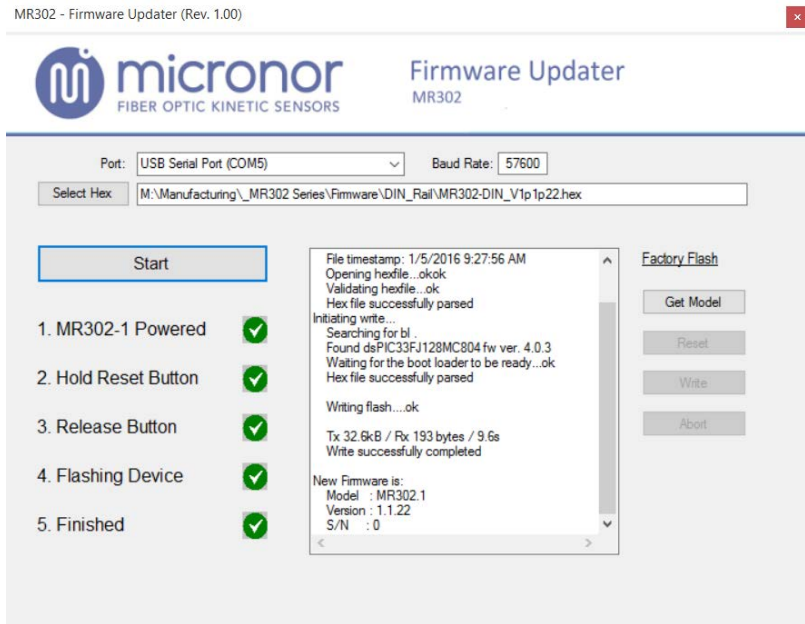

When the write is successfully completed you may disconnected the unit.

## 9.1 DAMAGED Firmware Recovery

If for some reason the firmware is damaged then the recovery is as follows:

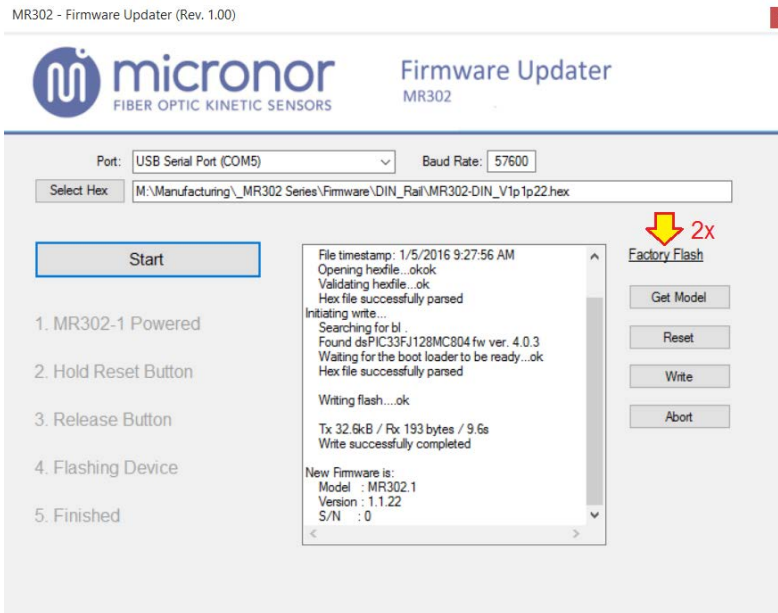

Disconnect sensor from Unit

Select appropriate Virtual Comport

Select Hex File with valid Firmware.

Double Click the “Factory Flash” label

Turn 24V power OFF

Push the MR302-1 Reset button and hold.

Turn 24V Power ON (keep button pressed)

Wait for 5 seconds and observe the red and green LED blink in alternating fashion.

Release the Reset button.

Within 3 seconds time click the Write Button on the software.

The software will start transmitting and writing the new firmware. Wait until completed.

## **10. Mechanical Reference Drawings**

These reference drawings can be found on the following pages.

**10.1 MR340-1 Controller**

**10.2 MR340 Series Declaration of Conformity**

REVISIONS				
REV	DATE	ECN NO.	DRAWN BY	DESCRIPTION
A	1-18-18	N/A	RGB	MR302-1 TO MR340-1
B	2-26-18	17017	RGB	OMIT SHUTTER, CHANGE SERIAL CONN.

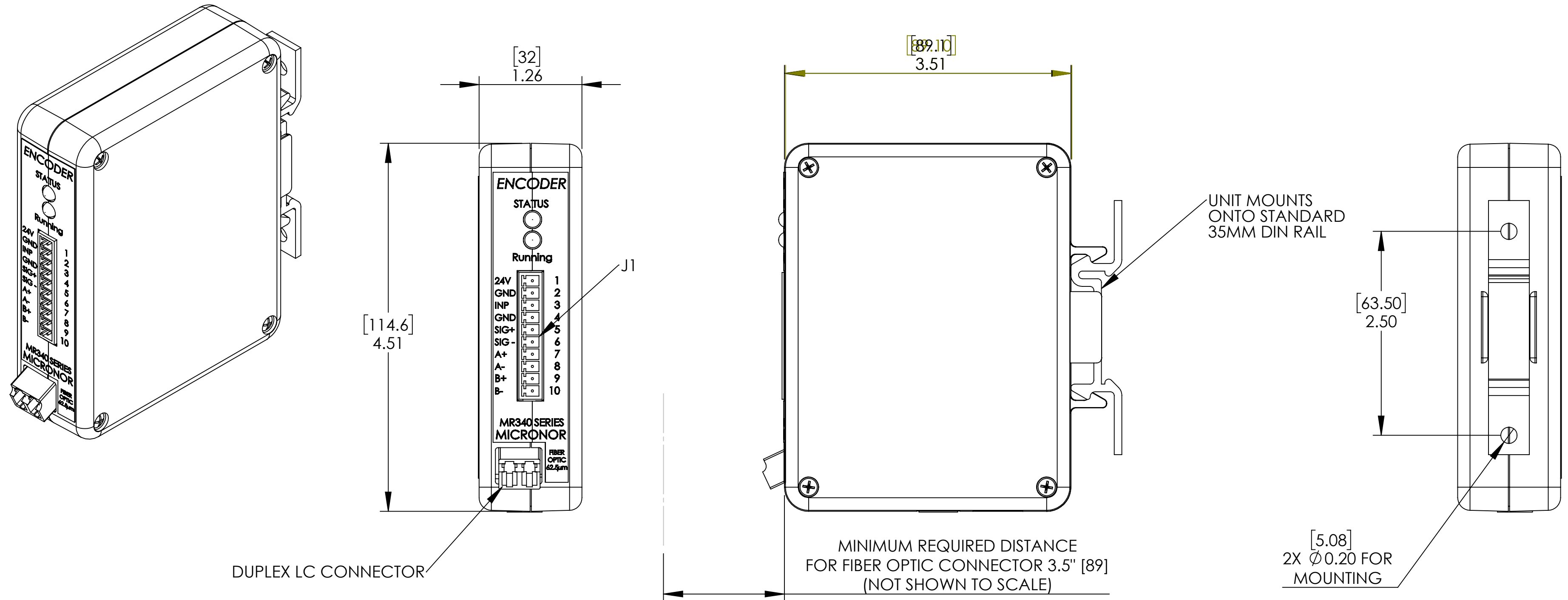

J1 PHOENIX 10 PIN RECEPTACLE P/N 1803358  
 PHOENIX MATING PLUG WITH SCREW TERMINALS P/N 1803659

TERMINAL	DESCRIPTION	
1	+24VDC	POWER SUPPLY 50MA TYP
2	GND	
3	INP	+24V HOMING INPUT FOR CALIBRATING ABSOLUTE POSITION
4	GND	
5	ANALOG OUT +	USER SELECTABLE: ±10V OR 4-20MA, POSITION OR SPEED
6	ANALOG OUT -	
7	ENCODER CH A+	USER SELECTABLE: 5V, 12V, 24V
8	ENCODER CH A -	
9	ENCODER CH B +	
10	ENCODER CH B -	

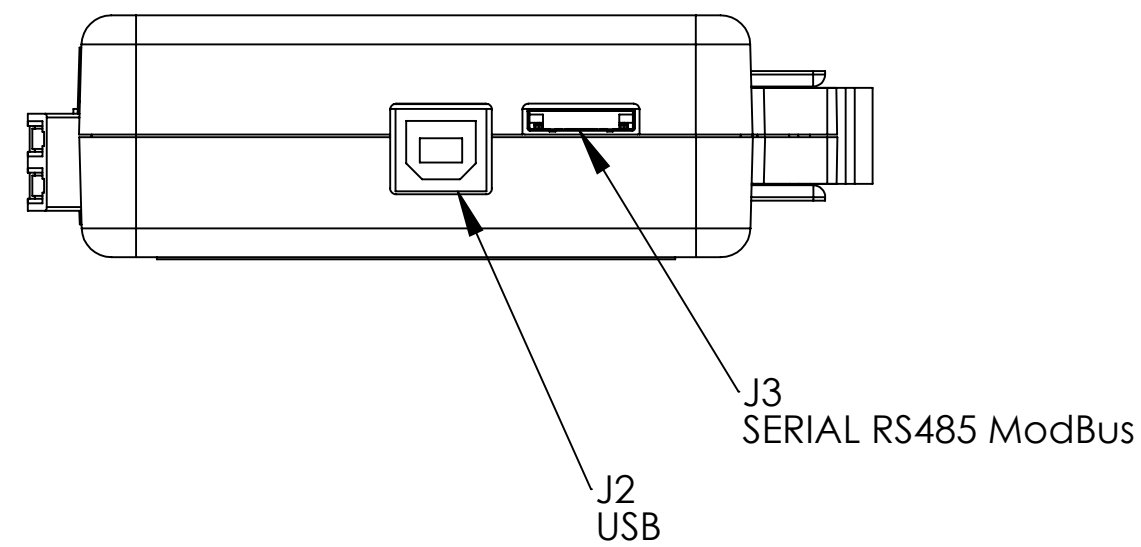

ORDERING CODE: MR340-1

1 MAKE SURE FIBER OPTIC PORT IS COVERED WHEN NOT IN USE.  
 NOTES: UNLESS OTHERWISE SPECIFIED

**PROPRIETARY AND CONFIDENTIAL**  
 THE INFORMATION CONTAINED IN THIS DRAWING IS THE SOLE PROPERTY OF MICRONOR INC. ANY REPRODUCTION IN PART OR AS A WHOLE WITHOUT THE WRITTEN PERMISSION OF MICRONOR INC. IS PROHIBITED.

UNLESS OTHERWISE SPECIFIED: DIMENSIONS ARE IN INCHES		 <b>micronor</b> <small>FIBER OPTIC KINETIC SENSORS</small>		<a href="http://WWW.MICRONOR.COM">WWW.MICRONOR.COM</a> 805 389 6600
TOLERANCES: TWO DECIMAL PLACE: ±.01 THREE DECIMAL PLACE: ±.004 FOUR DECIMAL PLACE: ±.0010 ANGULAR: ±.5°		TITLE: <b>MR340-1 CONTROLLER MODULE ENVELOPE</b>		
MATERIAL: SEE NOTES	FINISH: SEE NOTES	DO NOT SCALE DRAWING	SCALE: 1:1	SHEET: 1 OF 1
SIZE: <b>C</b>	DWG. NO.: <b>98-0340-51</b>	REV: <b>B</b>		



900 Calle Plano, Suite K  
 Camarillo, CA 93012 USA  
 T +1-805-389-6600  
 F +1-805-389-6605  
[www.micronor.com](http://www.micronor.com)

## Declaration of Conformity

**Micronor Inc.**  
 900 Calle Plano, Suite K, Camarillo, CA 93012, USA

declare that the product

<b>Fiber Optic Incremental Encoder System</b>	<b>Item Code(s)</b>
<b>Controllers</b>	MR340-0 (formerly MR302-2) MR340-1 (formerly MR302-1)
<b>Sensors</b>	MR341, MR342, MR343, MR344, MR345, MR346, MR348

**Country of Origin: Camarillo, CA USA**

to which this declaration relates in conformity with the following standards, normative documents and/or customer requirements:

<b>Requirement</b>	<b>MR340 Controller</b>	<b>MR340 Sensors</b>
1. Laser Safety	Class 1 laser device per IEC 60825	Exempt
2. ATEX Directive	Sensor and Controller are exempt: Not considered to have an independent source of ignition. (a) Optical sources which meet the Class I limits are considered suitable for use in locations with an EPL of Mb, Gb, Gc, Db or Dc as per Clause 1 (3) of IEC 60079-28:2015 Ed 2.	
3. Low Voltage Directive	Exempt	Exempt
4. EMC Directive	Passed	Exempt
5. CE Mark	Applicable	Applicable

Place: Camarillo, CA, USA

Date of Issue: 28-August-2018

Dennis Horwitz  
 Micronor Inc.  
 Vice President, Sales and Marketing  
[dennis@micronor.com](mailto:dennis@micronor.com)

Ref: J:\Declaration of Conformity\MR340 Controller DOC\MICRONOR\_98-0340-09\_A\_MR340 Declaration of Conformity\_INTERIM\_28-Aug-2018.docx